

REV.	DESCRIPTION	ECN NO.	NAME	DATE
0	FIRST EDITION	N/A	Flame	2022-08-22

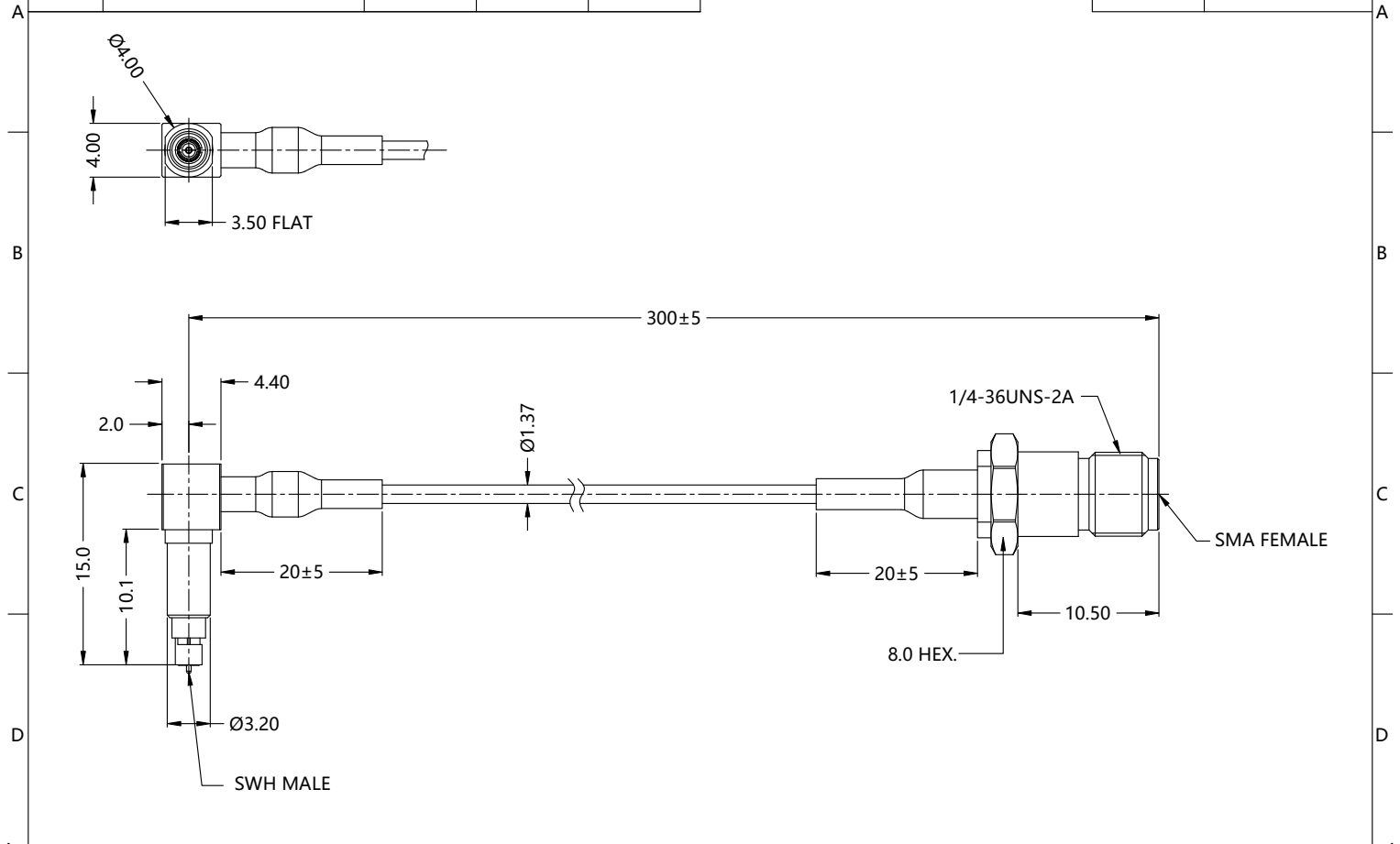

ALL PARTS MUST MEET TO RoHS REQUIREMENTS



MATERIALS AND PLATING		UNIT: MICRO-INCHES	
PART TYPE	PART NAME	MATERIALS	PLATING
SMA S/T FEMALE	BODY	BRASS C3604	PL.GOLD/NICKEL/COPPER
	INSULATOR	PTFE MIL-P-19468	N/A
	CONTACT PIN	BERYLLIUM COPPER	PL.GOLD/NICKEL/COPPER
SWH R/A MALE	BODY	BRASS C3604	PL.GOLD/NICKEL/COPPER
	INSULATOR	PTFE MIL-P-19468	N/A
	CONTACT PIN	BERYLLIUM COPPER	PL.GOLD/NICKEL/COPPER
CABLE	1.37 CABLE		
OTHER	N/A		

ELECTRICAL CHARACTERISTICS		
IMPEDANCE	50 Ω	
VOLTAGE RATING	170 V(rms)	
FREQUENCY RANGE	0 ~ 12GHz	
DIELECTRIC WITHSTANDING VOLTAGE	> 500 V	
CONTACT RESISTANCE	CENTER CONTACT	N/A
	OUTER CONTACT	N/A
INSULATION RESISTANCE	> 500 MΩ	
INSERTION LOSS	< 3.5dB @DC~12GHz	
VSWR	< 1.3 @ DC~8 GHz	
	< 1.5 @ 8~12 GHz	

MECHANICAL CHARACTERISTICS	
CABLE STATIC BENDING RADIUS	8mm MIN.
DURABILITY(SMA)	>500cycles
DURABILITY(SWH)	>200cycles

ENVIRONMENTAL PARAMETER	
TEMPERATURE RANGE	-40 °C ~ +80 °C
PROTECTION GRADE	N/A

\* CUSTOMER OUTLINE DRAWING

UNLESS OTHERWISE SPECIFIED: 1) EDGES : N/A ; 2) REMOVE ALL BURRS : N/A ; 3) SURFACE ROUGHNESS : N/A ; 4) UNITS : mm ; 5) DIMENSIONS TOLERANCES DECIMALS : .x ±5, .xx ±2, .xxx ±1; ANGLES : ±10°.	THIRD ANGLE PROJECTION		 TITLE : SWH MALE R/A TO SMA FEMALE S/T FOR 1.37 CABLE DRAWING NO. : T-MAFSWHMR077-030001 COMPANY WEBSITE : www.slkcorp.com
	APPROVED :	CUSTOMER P/N :	
	CHECKED :	SCALE :	2: 1
	DRAWING : Flame	DATE : 2022-08-22	PAGE : 1/1