

REV.	DESCRIPTION	ECN NO.	NAME	DATE	 ALL PARTS MUST MEET TO RoHS REQUIREMENTS
0	FIRST EDITION	N/A	YWD	2022-08-24	

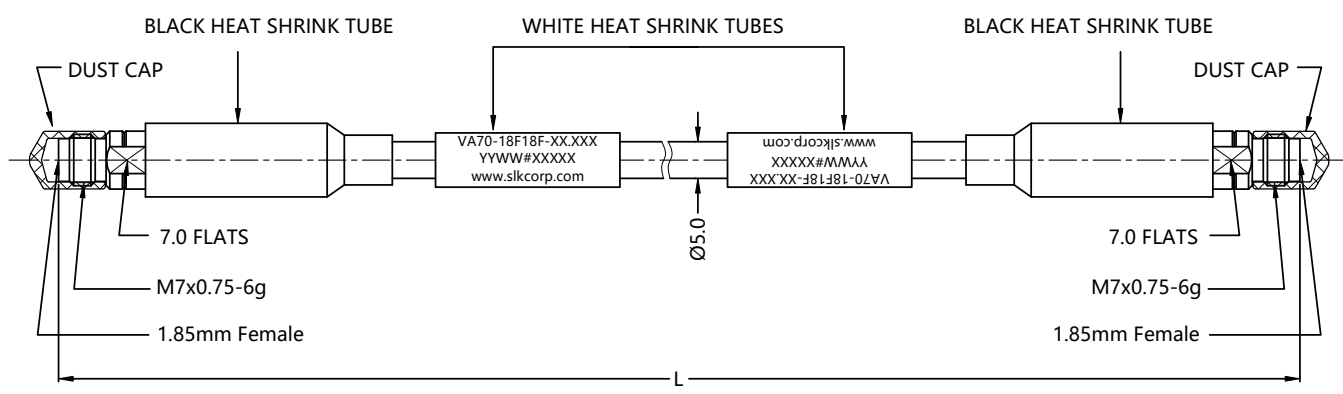

7	VA70-18F18F-02.00M	2000 ⁺³⁰ ₀	79.3	<12.9
6	VA70-18F18F-01.50M	1500 ⁺³⁰ ₀	59.6	<9.9
5	VA70-18F18F-04.00F	1220 ⁺³⁰ ₀	48.0	<8.3
4	VA70-18F18F-01.00M	1000 ⁺²⁰ ₀	39.8	<6.9
3	VA70-18F18F-03.00F	914 ⁺²⁰ ₀	36.0	<6.4
2	VA70-18F18F-02.00F	610 ⁺¹⁰ ₀	24.0	<4.6
1	VA70-18F18F-00.50M	500 ⁺¹⁰ ₀	19.9	<3.9
NO.	DRAWING NO.	L(LENGTH,mm)	L(LENGTH,INCH .REF)	INSERTION LOSS(dB)



MATERIALS AND PLATING UNIT: MICRO-INCHES			
PART TYPE	PART NAME	MATERIALS	PLATING
1.85mm FEMALE	BODY/SHELL	STAINLESS STEEL	PASSIVATION
	INSULATOR	PEI	N/A
	CONTACT PIN	BERYLLIUM COPPER	GOLD
CABLE	TEST CABLE		
ARMOR	PTFE STAINLESS STEEL SPRING ARMOR(BLACK+RED)		

ELECTRICAL CHARACTERISTICS	
IMPEDANCE	50 Ω
VOLTAGE RATING	170 V(rms)
FREQUENCY RANGE	DC ~ 70 GHz
DIELECTRIC WITHSTANDING VOLTAGE	> 500 V
INSULATION RESISTANCE	> 500 MΩ
INSERTION LOSS	See Tables
VSWR	< 1.35
RF- LEAKAGE	> 90 dB @DC~67GHz
MECHANICAL PHASE STABILITY	< ±5°
MECHANICAL AMPLITUDE STABILITY	< ±0.05 dB

MECHANICAL CHARACTERISTICS	
MIN. BENDING RADIUS ,STATIC	25 mm
MIN. BENDING RADIUS ,REPEATED	60 mm
RECOMMENDED COUPLING TORQUE	N/A
COUPLING NUT RETENTION FORCE	N/A
CABLE RETENTION FORCE	> 30 lbs
CRUSH RESISTANCE	40 KN/M
DURABILITY	> 500 cycles

ENVIRONMENTAL PARAMETER	
TEMPERATURE RANGE	-40 °C~+85 °C

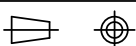
CUSTOMER OUTLINE DRAWING

* CUSTOMER OUTLINE DRAWING		THIRD ANGLE PROJECTION 		 TITLE : 1.85mm FEMALE S/T TO 1.85mm FEMALE S/T FOR TEST CABLE DRAWING NO. : VA70-18F18F-XX.XXX(SEE TABLE) COMPANY WEBSITE : www.slkcorp.com
UNLESS OTHERWISE SPECIFIED: 1) EDGES : N/A ; 2) REMOVE ALL BURRS : N/A ; 3) SURFACE ROUGHNESS : N/A ; 4) UNITS : mm ; 5) DIMENSIONS TOLERANCES DECIMALS : .x ±5, .xx ±2, .xxx±1; ANGLES : ±10°.		APPROVED :	CUSTOMER P/N :	
		CHECKED :	SCALE : 1 : 1	
		DRAWING :	DATE : 2022-08-24	