

REV.	DESCRIPTION	ECN NO.	NAME	DATE	 ALL PARTS MUST MEET TO RoHS REQUIREMENTS
6	UPDATE THE DRAWING	N/A	YJY	2019-04-22	
7	NEW FRAME	N/A	JING	2020-05-14	

REMARKS:
 1.CONTACT PIN TO SOLDER
 2.OUTER CONTACT TO SOLDER
 3.CRIMPED FERRULE HEX. CRIMP SIZE 2.5mm HEX.

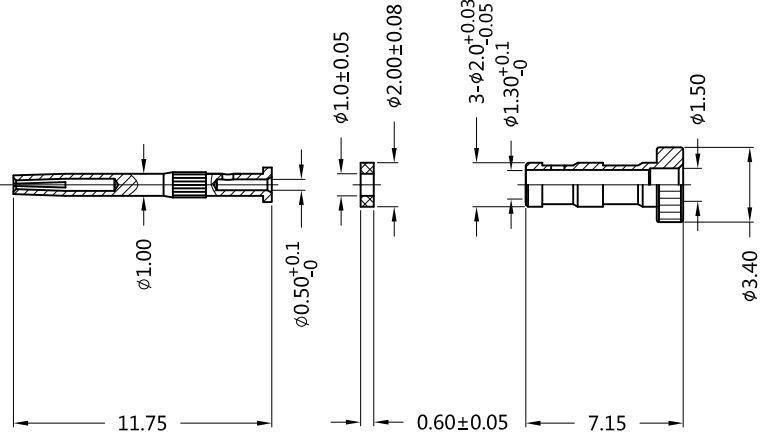
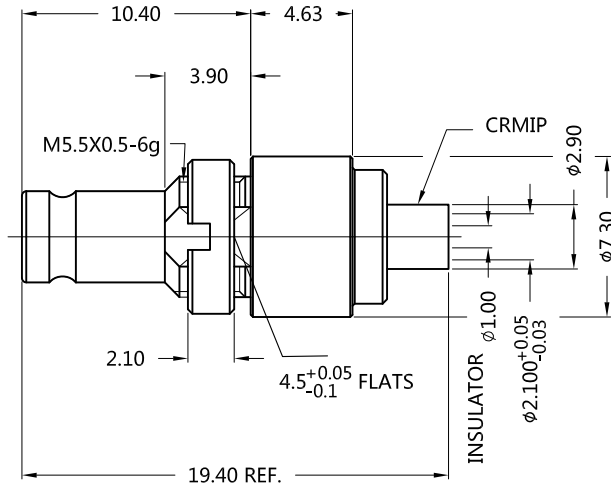
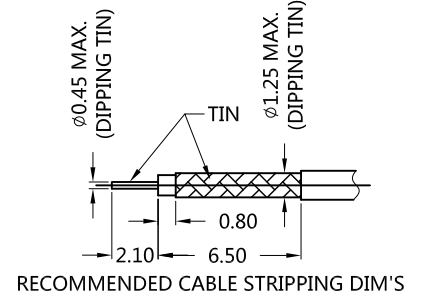
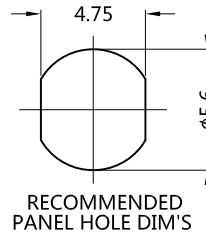

MATERIALS AND PLATING		UNIT: MICRO-INCHES
PART NAME	MATERIALS	PLATING
BODY	BRASS C3602	GOLD PL.8u"/NICKEL/COPPER
INSULATOR	PTFE ASTM-D-1710	N/A
CONTACT PIN	PHOSPHOR BRONZE	GOLD PL.30u"/NICKEL/COPPER
BARREL	BRASS 3602	GOLD PL.8u"/NICKEL/COPPER
NUT	BRASS 3604	GOLD FLASH/NICKEL/COPPER
FERRULE	BRASS 3604	GOLD PL.8u"/NICKEL/COPPER

ELECTRICAL CHARACTERISTICS		
IMPEDANCE	50 Ω	
VOLTAGE RATING	250 V(rms)	
FREQUENCY RANGE	0 ~ 4 GHz	
DIELECTRIC WITHSTANDING VOLTAGE	>750V	
CONTACT RESISTANCE	CENTER CONTACT	<10.0 mΩ
	OUTER CONTACT	<3.0 mΩ
INSULATION RESISTANCE	>200 MΩ	
INSERTION LOSS	N/A	
RF-LEAKAGE	N/A	
WSWR	<1.25@DC-2.2 GHZ	
3RD INTERMODULATION	N/A	

MECHANICAL CHARACTERISTICS	
CABLE RETENTION FORCE	>1.5kg(1PC 620)
CENTER CONTACT RETENTION FORCE	N/A
RECOMMENDED COUPLING TORQUE	<9kgf.cm
COUPLING NUT RETENTION FORCE	N/A
DURABILITY	>500 cycles

ENVIRONMENTAL PARAMETER	
TEMPERATURE RANGE	-65 °C ~ +165 °C
INTERFACE STANDARD	IEC61169-29

* CUSTOMER OUTLINE DRAWING

UNLESS OTHERWISE SPECIFIED:
 1) EDGES : C0.15 MAX ;
 2) REMOVE ALL BURRS ;
 3) SURFACE ROUGHNESS : Ra1.6 ;
 4) UNITS : mm ;
 5) DIMENSIONS TOLERANCES
 DECIMALS : .x ±0.3 .xx ±0.2 .xxx±0.1;
 ANGLES : ± 5°.

THIRD ANGLE PROJECTION

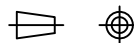

APPROVED :

CUSTOMER P/N :

CHECKED :

SCALE :

DRAWING : JING

DATE : 2019-04-16

PAGE : 1/1



TITLE : 1.0/2.3 FEMALL S/T FOR Ø1.37 CABLE

DRAWING NO. : 5A1F15S-A72-001

COMPANY WEBSITE : www.slkcorp.com

CUSTOMER OUTLINE DRAWING