

REV.	DESCRIPTION	ECN NO.	NAME	DATE
3	NEW FRAME	N/A	JING	2020-08-20

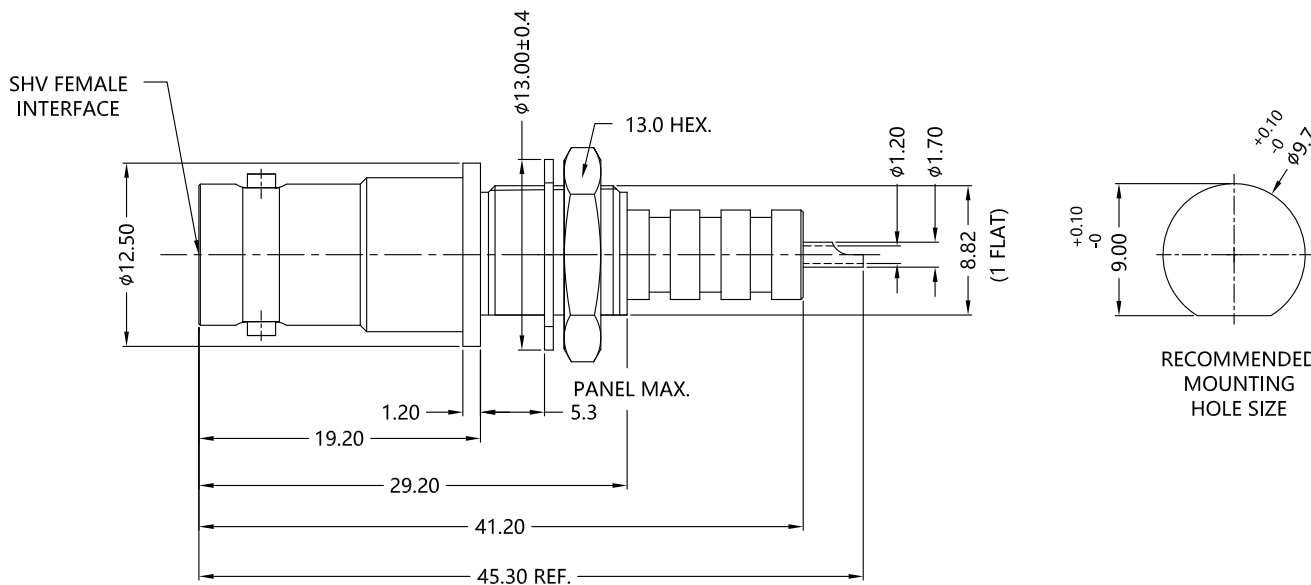

ALL PARTS MUST MEET TO RoHS REQUIREMENTS



MATERIALS AND PLATING		UNIT: MICRO-INCHES
PART NAME	MATERIALS	PLATING
BODY	BRASS C3604	ALBALOY 300u"/COPPER
INSULATOR	PTFE ASTM-D-1710	N/A
CONTACT PIN	BRASS	GOLD 50"/NICKEL/COPPER
NUT	BRASS	ALBALOY 100u"/COPPER
WASHER	STEEL	ALBALOY 300u"/COPPER

ELECTRICAL CHARACTERISTICS	
IMPEDANCE	50 Ω
VOLTAGE RATING	3660 V(rms)
FREQUENCY RANGE	0 ~ 300 MHz
DIELECTRIC WITHSTANDING VOLTAGE	>5000 V
CONTACT RESISTANCE	CENTER CONTACT <2.0 m Ω
	OUTER CONTACT <1.5 m Ω
INSULATION RESISTANCE	>5000 M Ω
INSERTION LOSS	N/A
RF-LEAKAGE	N/A
VSWR	<1.30
3RD INTERMODULATION	N/A

MECHANICAL CHARACTERISTICS	
FORCE TO ENGAGE AND DISENGAGE	N/A
CENTER CONTACT RETENTION FORCE	>6 lbs
RECOMMENDED COUPLING TORQUE	N/A
COUPLING NUT RETENTION FORCE	N/A
DURABILITY	>500 cycles

ENVIRONMENTAL PARAMETER	
TEMPERATURE RANGE	-65 $^{\circ}$ C ~ +165 $^{\circ}$ C

* CUSTOMER OUTLINE DRAWING

UNLESS OTHERWISE SPECIFIED:
 1) EDGES : C0.15 MAX ;
 2) REMOVE ALL BURRS ;
 3) SURFACE ROUGHNESS : Ra1.6 ;
 4) UNITS : mm ;
 5) DIMENSIONS TOLERANCES
 DECIMALS : .x ± 0.3 .xx ± 0.2 .xxx ± 0.1 ;
 ANGLES : $\pm 5^{\circ}$.

THIRD ANGLE PROJECTION

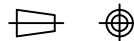

APPROVED :	CUSTOMER P/N :
CHECKED :	SCALE :
DRAWING :	DATE :
JING	2020-08-20
	PAGE : 1/1

CUSTOMER P/N :	-
SCALE :	2 : 1
DATE :	2020-08-20
PAGE :	1/1



TITLE : SHV FEMALE BULKHEAD SOCKET FRONT MOUNTING , 50 Ω

DRAWING NO. : 5SHF11S-A00-001

COMPANY WEBSITE : www.slkcorp.com

CUSTOMER OUTLINE DRAWING