

REV.	DESCRIPTION	ECN NO.	NAME	DATE	 ALL PARTS MUST MEET TO RoHS REQUIREMENTS
0	FIRST EDITION	N/A	WYJ	2018-08-28	
1	NEW FRAME	N/A	JING	2020-05-14	

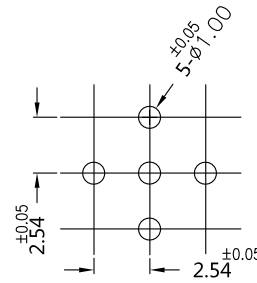
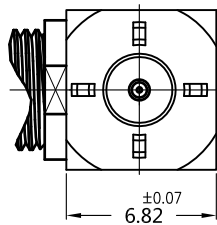
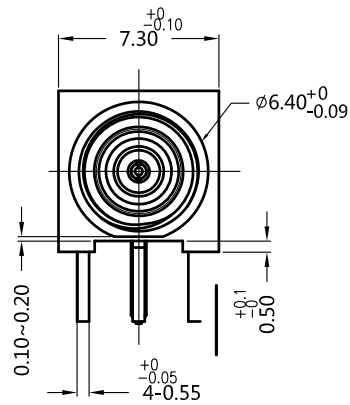
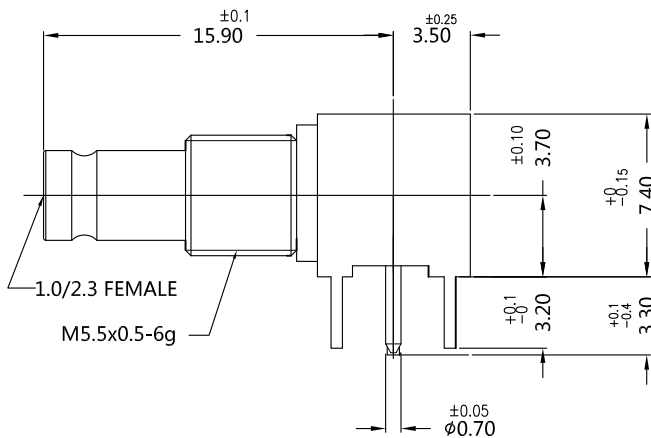

PCB ASSIGNMENT

MATERIALS AND PLATING		UNIT: MICRO-INCHES
PART NAME	MATERIALS	PLATING
BODY 1	BRASS C3604	GOLD15u"MIN/NICKEL/COPPER
INSULATOR	PTFE ASTM-D-1710	N/A
CONTACT PIN	BERYLIUM COPPER	GOLD15u"MIN/NICKEL/COPPER
BODY 2	BRASS C3604	ALBALOY 160 U"/COPPER

ELECTRICAL CHARACTERISTICS	
IMPEDANCE	50 Ω
VOLTAGE RATING	250 V(rms)
FREQUENCY RANGE	0 ~ 6 GHz
DIELECTRIC WITHSTANDING VOLTAGE	>750V
CONTACT RESISTANCE	CENTER CONTACT <4.0 m Ω
	OUTER CONTACT <2.5 m Ω
INSULATION RESISTANCE	>1000 M Ω
INSERTION LOSS	N/A
RF-LERKAGE	N/A
VSWR	<1.5
3RD INTERMODULATION	N/A

MECHANICAL CHARACTERISTICS	
FORCE TO ENGAGE AND DISENGAGE	N/A
CENTER CONTACT RETENTION FORCE	>2.25 lbs
RECOMMENDED COUPLING TORQUE	>10 N · cm
COUPLING NUT RETENTION FORCE	N/A
DURABILITY	>500 cycles

ENVIRONMENTAL PARAMETER	
TEMPERATURE RANGE	-45 °C ~ +85 °C
SALT SPRAY	48H

* CUSTOMER OUTLINE DRAWING

UNLESS OTHERWISE SPECIFIED:

- 1) EDGES : C0.15 MAX ;
- 2) REMOVE ALL BURRS ;
- 3) SURFACE ROUGHNESS : Ra1.6 ;
- 4) UNITS : mm ;
- 5) DIMENSIONS TOLERANCES
 DECIMALS : .x ± 0.2 .xx ± 0.1 .xxx ± 0.05 ;
 ANGLES : $\pm 5^\circ$.

THIRD ANGLE PROJECTION

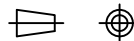

APPROVED :

CUSTOMER P/N :

CHECKED :

SCALE :

3 : 1

DRAWING :

JING

DATE : 2020-05-14

PAGE : 1/1



TITLE : 1.0/2.3 FEMALE 50OHMS FOR PCB MOUNTING

DRAWING NO. :

5A1F25R-P41-009

COMPANY WEBSITE : www.slkcorp.com

CUSTOMER OUTLINE DRAWING