

REV.	DESCRIPTION	ECN NO.	NAME	DATE
1	UPDATE DRAWING	N/A	Kevin.Li	2021-06-04
2	UPDATE DRAWING	N/A	Kevin.Li	2021-06-16
3	UPDATE VSWR	N/A	LEI CHAO	2021-07-26

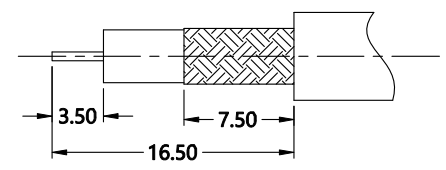

ALL PARTS MUST MEET TO RoHS REQUIREMENTS

1. CRIMPED FERRULE HEX: CRIMP SIZE .255"
2. CRIMP CONTACT PIN FOR .061" HEX
3. THE PLATING THICKNESS IS MINIMUM



RECOMMENDED CABLE STRIPPING DIM'S

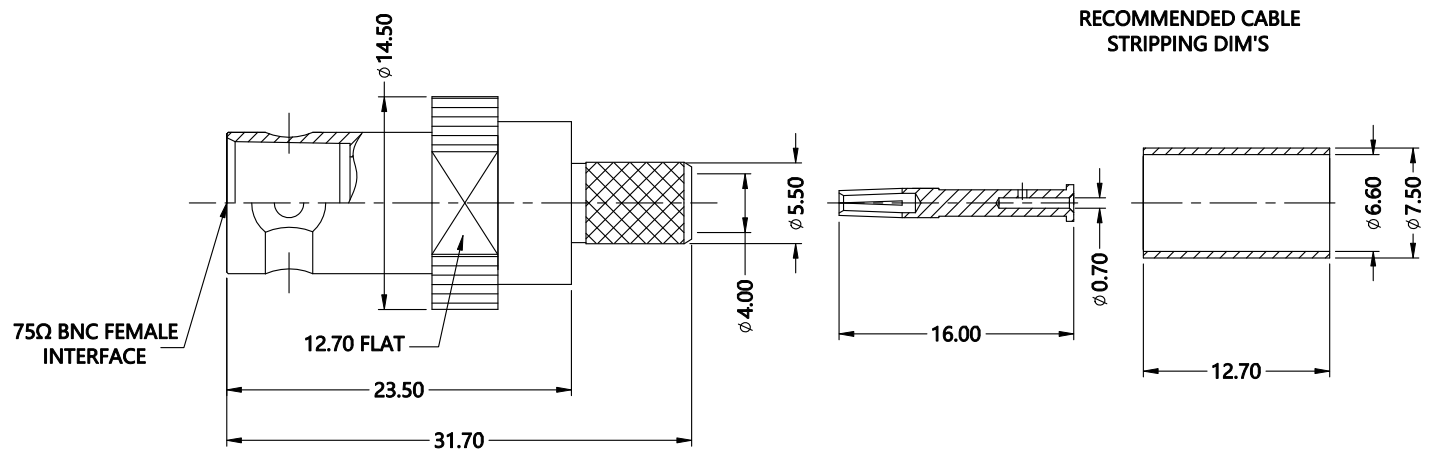

75Ω BNC FEMALE INTERFACE

MATERIALS AND PLATING		UNIT: MICRO-INCHES
PART NAME	MATERIALS	PLATING
BODY	BRASS	NICKEL 100u*/COPPER
INSULATOR	PTFE	N/A
CONTACT PIN	PHOSPHOR BRONZE	GOLD 3u*/NICKEL 100u*/COPPER

ELECTRICAL CHARACTERISTICS	
IMPEDANCE	75 Ω
VOLTAGE RATING	500 V(rms)
FREQUENCY RANGE	0 ~ 2 GHz
DIELECTRIC WITHSTANDING VOLTAGE	>1500 V
CONTACT RESISTANCE	CENTER CONTACT <1.5 mΩ
	OUTER CONTACT <0.2 mΩ
INSULATION RESISTANCE	>5000 MΩ
INSERTION LOSS	0.20 dB max
VSWR	< 1.20 Δ 3
3RD INTERMODULATION	N/A

MECHANICAL CHARACTERISTICS	
FORCE TO ENGAGE AND DISENGAGE	N/A
CENTER CONTACT RETENTION FORCE	N/A
RECOMMENDED COUPLING TORQUE	N/A
COUPLING NUT RETENTION FORCE	N/A
DURABILITY	> 500cycles
CABLE RETENTION FORCE	170 N min

ENVIRONMENTAL PARAMETER	
TEMPERATURE RANGE	-65 °C~+165 °C
THERMAL SHOCK	MIL- STD 202, Meth. 107,Cond. B
VIBRATION	MIL- STD 202, Meth. 204,Cond. B
SHOCK	MIL- STD 202, Meth. 213,Cond. I

* CUSTOMER OUTLINE DRAWING

UNLESS OTHERWISE SPECIFIED:
 1) EDGES : C0.15 MAX ;
 2) REMOVE ALL BURRS ;
 3) SURFACE ROUGHNESS : Ra1.6 ;
 4) UNITS : mm ;
 5) DIMENSIONS TOLERANCES
 DECIMALS : .x ±0.2 .xx ±0.1 .xxx±0.05;
 ANGLES : ± 5°.

THIRD ANGLE PROJECTION	
APPROVED :	CUSTOMER P/N : 1-1337443-0
CHECKED :	SCALE : -
DRAWING :	DATE : 2021-07-26
	PAGE : 1/1

TITLE : BNC FEMALE S/T CRIMP FOR RG59 CABLE,75Ω
 DRAWING NO. : 7BNF11S-A10-001
 COMPANY WEBSITE : www.slkcorp.com

CUSTOMER OUTLINE DRAWING