

1	2	3	4	5	6
REV.	DESCRIPTION	ECN NO.	NAME	DATE	
0	FIRST EDITION	N/A	WG	2018-06-01	 ALL PARTS MUST MEET TO RoHS REQUIREMENTS
1	NEW FRAME	N/A	HYH	2020-06-20	

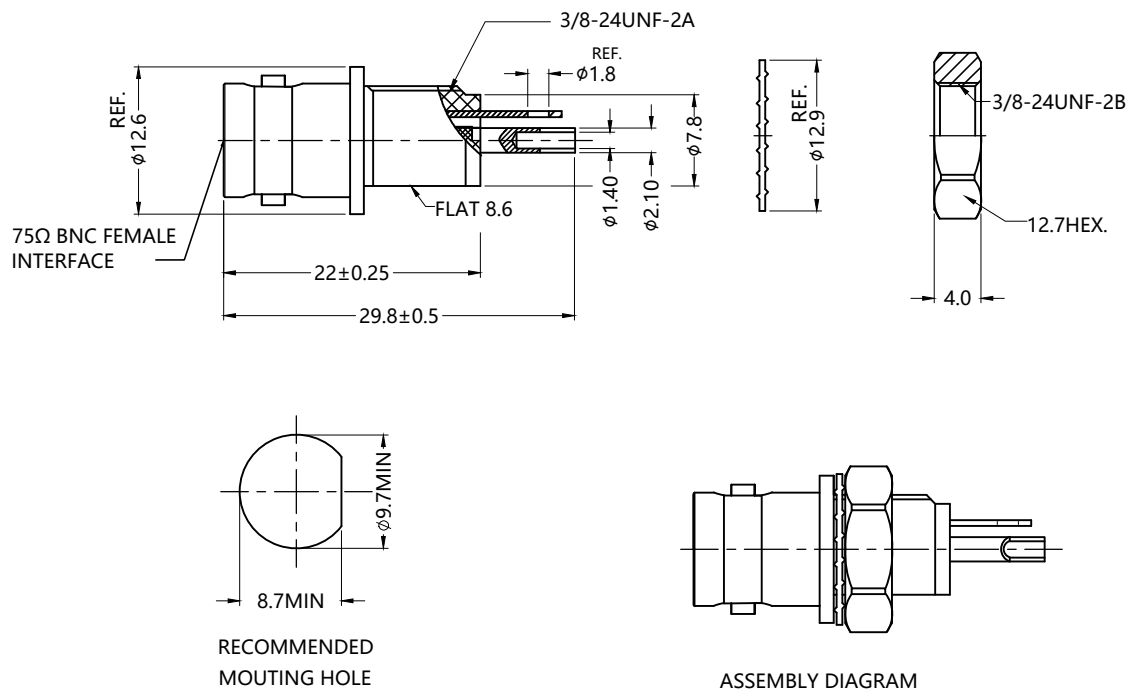

MATERIALS AND PLATING		UNIT: MICRO-INCHES
PART NAME	MATERIALS	PLATING
BODY B	BRASS	NICKEL PL.100u"/COPPER
WASHER	BRASS	NICKEL PL.100u"/COPPER
GROUNDING TAB	BRASS	TIN PL.200u"/COPPER
BODY A	ABS NATURAL	FIRE RATING 94V0
CONTACT PIN	PHOSPHOR BRONZE	SLIVER PL.40u"/COPPER
LOCKWASHER	STEEL	NICKEL PL.100u"/COPPER
HEX NUT	BRASS	NICKEL PL.100u"/COPPER

ELECTRICAL CHARACTERISTICS	
IMPEDANCE	75 Ω
WORKING VOLTAGE	500 V(rms)
FREQUENCY RANGE	0 ~ 1.0 GHz
DIELECTRIC WITHSTANDING VOLTAGE	>1500 V
CONTACT RESISTANCE	CENTER CONTACT
	OUTER CONTACT
INSULATION RESISTANCE	>5000 MΩ
INSERTION LOSS	<0.5 dB @0-300 MHz
VSWR	<1.5 @0-300 GHz
3RD INTERMODULATION	N/A

MECHANICAL CHARACTERISTICS	
CENTER CONTACT RETENTION TORQUE	N/A
CENTER CONTACT RETENTION FORCE	> 6 lbs
INSULATOR RETENTION FORCE	>6 lbs
MOUNT NUT RECOMMENDED TORQUE	N/A
DURABILITY	> 500 cycles

ENVIRONMENTAL PARAMETER	
TEMPERATURE RANGE	-40 °C ~ +60 °C

*** CUSTOMER OUTLINE DRAWING**

UNLESS OTHERWISE SPECIFIED: 1) EDGES : C0.15 MAX ; 2) REMOVE ALL BURRS ; 3) SURFACE ROUGHNESS : Ra1.6 ; 4) UNITS : mm ; 5) DIMENSIONS TOLERANCES DECIMALS : .x ±0.3 .xx ±0.2 .xxx±0.1; ANGLES : ± 5°.	THIRD ANGLE PROJECTION		 SUPERLINK	
	APPROVED :	CUSTOMER P/N :		TITLE : BNC FEMALE S/T SOLDER CUP,BULKHEAD-FRONT MOUNT,75Ω
	CHECKED :	SCALE :	DRAWING NO. :	
	DRAWING : HYH	DATE : 2020-06-20	7BNF45S-T00	COMPANY WEBSITE : www.slkcorp.com

CUSTOMER OUTLINE DRAWING