

REV.	DESCRIPTION	ECN NO.	NAME	DATE
A0	FIRST EDITION	N/A	YWD	2017-07-13
A1	NEW FRAME	N/A	JING	2020-06-28

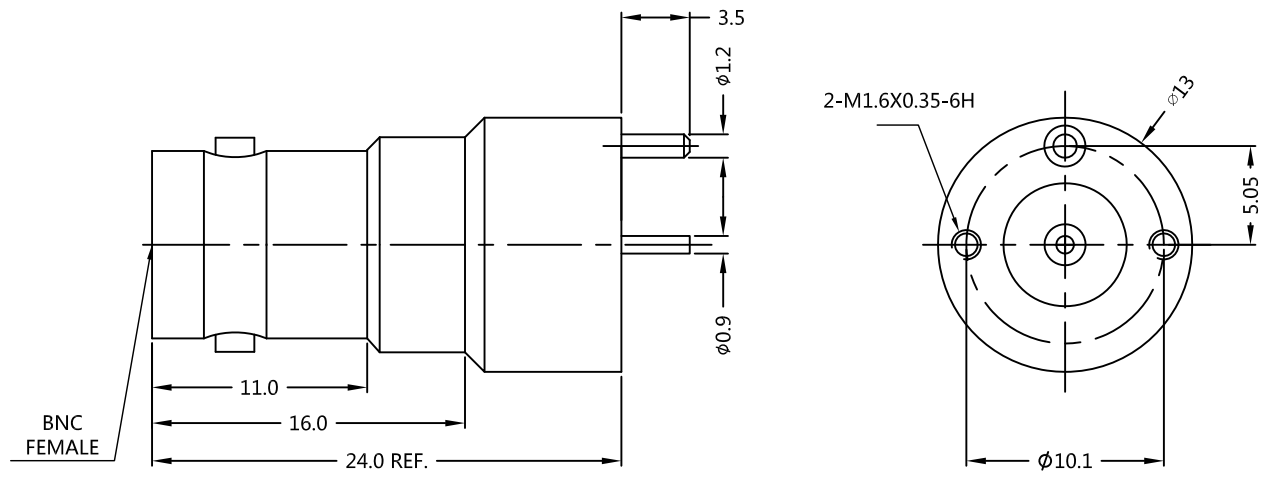

ALL PARTS MUST MEET TO RoHS REQUIREMENTS



MATERIALS AND PLATING		UNIT: MICRO-INCHES
PART NAME	MATERIALS	PLATING
BODY	BRASS C3602	MISTINESS NICKEL 200u"/COPPER
INSULATOR	PTFE ASTM-D-1710	N/A
CONTACT PIN	PHOSPHOR BRONZE	GOLD 3 u"/NICKEL/COPPER
PIN LEG	BRASS C3604	BRIGHT TIN 200u"/NICKEL/COPPER

ELECTRICAL CHARACTERISTICS	
IMPEDANCE	50 Ω
VOLTAGE RATING	500 V(rms)
FREQUENCY RANGE	0 ~ 4 GHz
DIELECTRIC WITHSTANDING VOLTAGE	>750 V
CONTACT RESISTANCE	CENTER CONTACT <6.0 mΩ
	OUTER CONTACT <3.0 mΩ
INSULATION RESISTANCE	>5000 MΩ
INSERTION LOSS	N/A
RF-LEAKAGE	N/A
VSWR	N/A
3RD INTERMODULATION	N/A

MECHANICAL CHARACTERISTICS	
FORCE TO ENGAGE AND DISENGAGE	N/A
CENTER CONTACT RETENTION FORCE	>6 lbs
RECOMMENDED COUPLING TORQUE	N/A
COUPLING NUT RETENTION FORCE	N/A
DURABILITY	>500 cycles

ENVIRONMENTAL PARAMETER	
TEMPERATURE RANGE	-55 °C ~ +125 °C

CUSTOMER OUTLINE DRAWING

*** CUSTOMER OUTLINE DRAWING**

UNLESS OTHERWISE SPECIFIED:
 1) EDGES : C0.15 MAX ;
 2) REMOVE ALL BURRS ;
 3) SURFACE ROUGHNESS : Ra1.6 ;
 4) UNITS : mm ;
 5) DIMENSIONS TOLERANCES
 DECIMALS : .x ±0.3 .xx ±0.2 .xxx±0.1;
 ANGLES : ± 5°.

THIRD ANGLE PROJECTION		
APPROVED :	CUSTOMER P/N :	-
CHECKED :	SCALE :	2 : 1
DRAWING :	DATE :	2020-06-28
JING	PAGE :	1/1

TITLE : BNC FEMALE S/T FOR PCB Through Hole 50 OHM
 DRAWING NO. : 5BNF25S-P00-004
 COMPANY WEBSITE : www.slkcorp.com