

REV.	DESCRIPTION	ECN NO.	NAME	DATE
0	FIRST EDITION	N/A	FJ	2017-07-06
1	NEW FRAME	N/A	LEI CHAO	2020-07-01

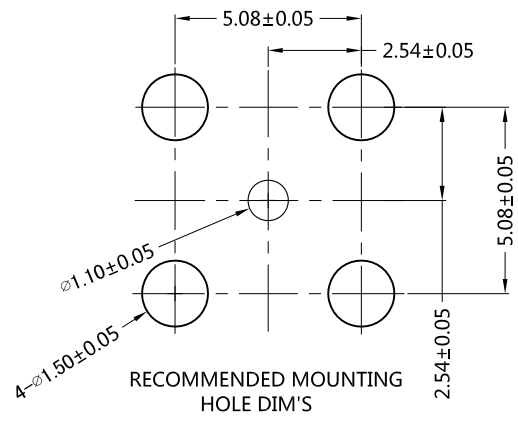

ALL PARTS MUST MEET TO RoHS REQUIREMENTS

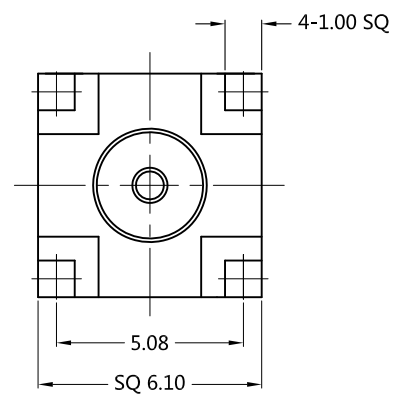
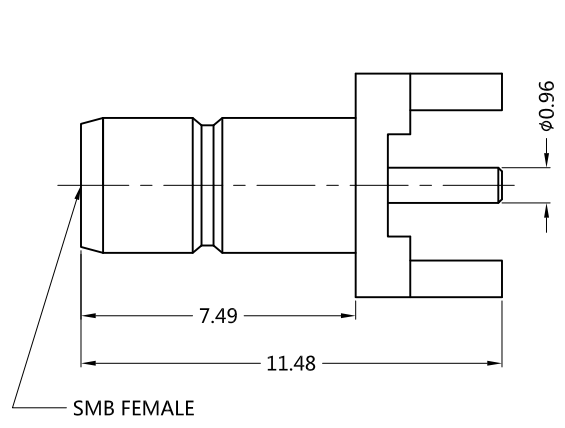

MATERIALS AND PLATING		UNIT: MICRO-INCHES
PART NAME	MATERIALS	PLATING
BODY	BRASS C3604	GOLD 3 u"/NICKEL/COPPER
INSULATOR	PTFE MIL-P-19468	N/A
CONTACT PIN	BRASS C3604	GOLD 10 u"/NICKEL /COPPER

ELECTRICAL CHARACTERISTICS	
IMPEDANCE	50 Ω
VOLTAGE RATING	250 V(rms)
FREQUENCY RANGE	DC ~ 4 GHz
DIELECTRIC WITHSTANDING VOLTAGE	>750 V
CONTACT RESISTANCE	CENTER CONTACT <6.0 mΩ
	OUTER CONTACT <1.0 mΩ
INSULATION RESISTANCE	>1000 MΩ
INSERTION LOSS	N/A
VSWR	N/A
3RD INTERMODULATION	N/A

MECHANICAL CHARACTERISTICS	
FORCE TO ENGAGE AND DISENGAGE	N/A
CENTER CONTACT RETENTION FORCE	> 4 lbs
RECOMMENDED COUPLING TORQUE	N/A
COUPLING NUT RETENTION FORCE	N/A
DURABILITY	> 500 cycles

ENVIRONMENTAL PARAMETER	
TEMPERATURE RANGE	-65 °C~+165 °C

*** CUSTOMER OUTLINE DRAWING**

UNLESS OTHERWISE SPECIFIED:
 1) EDGES : C0.15 MAX ;
 2) REMOVE ALL BURRS ;
 3) SURFACE ROUGHNESS : Ra1.6 ;
 4) UNITS : mm ;
 5) DIMENSIONS TOLERANCES
 DECIMALS : .x ±0.3 .xx ±0.2 .xxx±0.1;
 ANGLES : ± 5°.

THIRD ANGLE PROJECTION	
APPROVED :	CUSTOMER P/N :
CHECKED :	SCALE :
DRAWING :	DATE :
PAGE : 1/1	

TITLE : SMB FEMALE S/T FOR PCB Through Hole ,50 Ω
 DRAWING NO. : 5MBF20S-P10
 COMPANY WEBSITE : www.slkcorp.com

CUSTOMER OUTLINE DRAWING