

REV.	DESCRIPTION	ECN NO.	NAME	DATE
0	FIRST EDITION	N/A	PY	2020-06-09
1	UPDATE THE DRAWING	N/A	PY	2020-06-22
2	UPDATE THE DRAWING	N/A	PY	2021-09-08

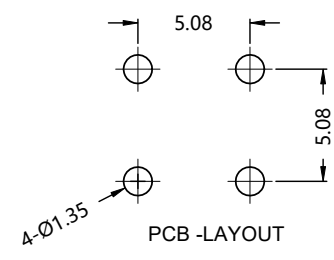

ALL PARTS MUST MEET TO RoHS REQUIREMENTS

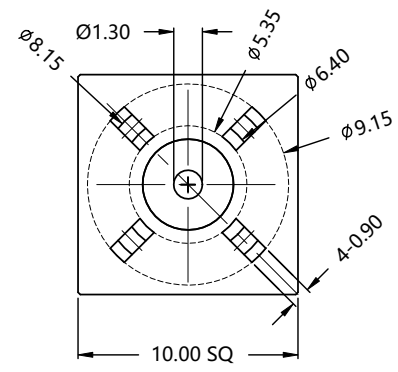
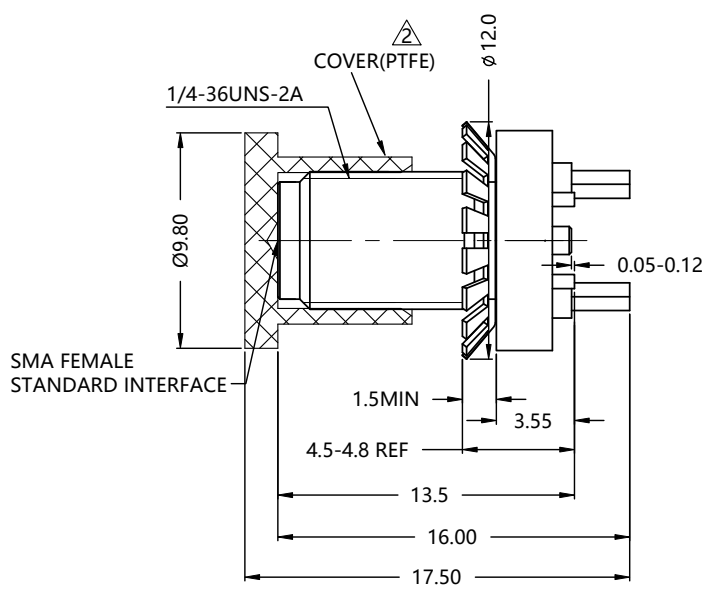

MATERIALS AND PLATING		UNIT: MICRO-INCHES
PART NAME	MATERIALS	PLATING
BODY	BRASS C3604	GOLD 3μ " / NICKEL/COPPER
INSULATOR	PTFE ASTM-D-1710	N/A
CONTACT PIN	BERYLLIUM COPPER	GOLD 10μ " / NICKEL/COPPER
WASHER	STAINLESS STEEL	PASSIVATE

ELECTRICAL CHARACTERISTICS		
IMPEDANCE	50 Ω	
VOLTAGE RATING	335 V(rms)	
FREQUENCY RANGE	DC ~ 6 GHz	
DIELECTRIC WITHSTANDING VOLTAGE	> 500 V	
CONTACT RESISTANCE	CENTER CONTACT	< 3.0 mΩ
	OUTER CONTACT	< 2.0 mΩ
INSULATION RESISTANCE	> 5000 MΩ	
INSERTION LOSS	N/A	
VSWR	< 1.15 @ DC~6 GHz	
3RD INTERMODULATION	N/A	

MECHANICAL CHARACTERISTICS	
FORCE TO ENGAGE AND DISENGAGE	N/A
CENTER CONTACT RETENTION FORCE	> 6 lbs
RECOMMENDED COUPLING TORQUE	N/A
COUPLING NUT RETENTION FORCE	N/A
DURABILITY	> 500cycles

ENVIRONMENTAL PARAMETER	
TEMPERATURE RANGE	-55 °C ~ +125 °C

* CUSTOMER OUTLINE DRAWING

UNLESS OTHERWISE SPECIFIED:
 1) EDGES : C0.15 MAX ;
 2) REMOVE ALL BURRS ;
 3) SURFACE ROUGHNESS : Ra1.6 ;
 4) UNITS : mm ;
 5) DIMENSIONS TOLERANCES
 DECIMALS : .x ±0.3 .xx ±0.2 .xxx ±0.1 ;
 ANGLES : ± 5°.

THIRD ANGLE PROJECTION	
APPROVED :	CUSTOMER P/N :
CHECKED :	SCALE :
DRAWING :	DATE :
PAGE : 1/1	

TITLE :	SMA FEMALE S/T FOR PCB SMT,50Ω
DRAWING NO. :	5MAF25S-P01-054
COMPANY WEBSITE :	www.slkcorp.com

REV.	DESCRIPTION	ECN NO.	NAME	DATE	 ALL PARTS MUST MEET TO RoHS REQUIREMENTS
0	FIRST EDITION	N/A	PY	2021-06-09	
1	UPDATE THE DRAWING	N/A	PY	2020-06-22	
2	UPDATE THE DRAWING	N/A	PY	2021-09-08	

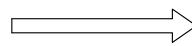
Direction of loading and unloading 

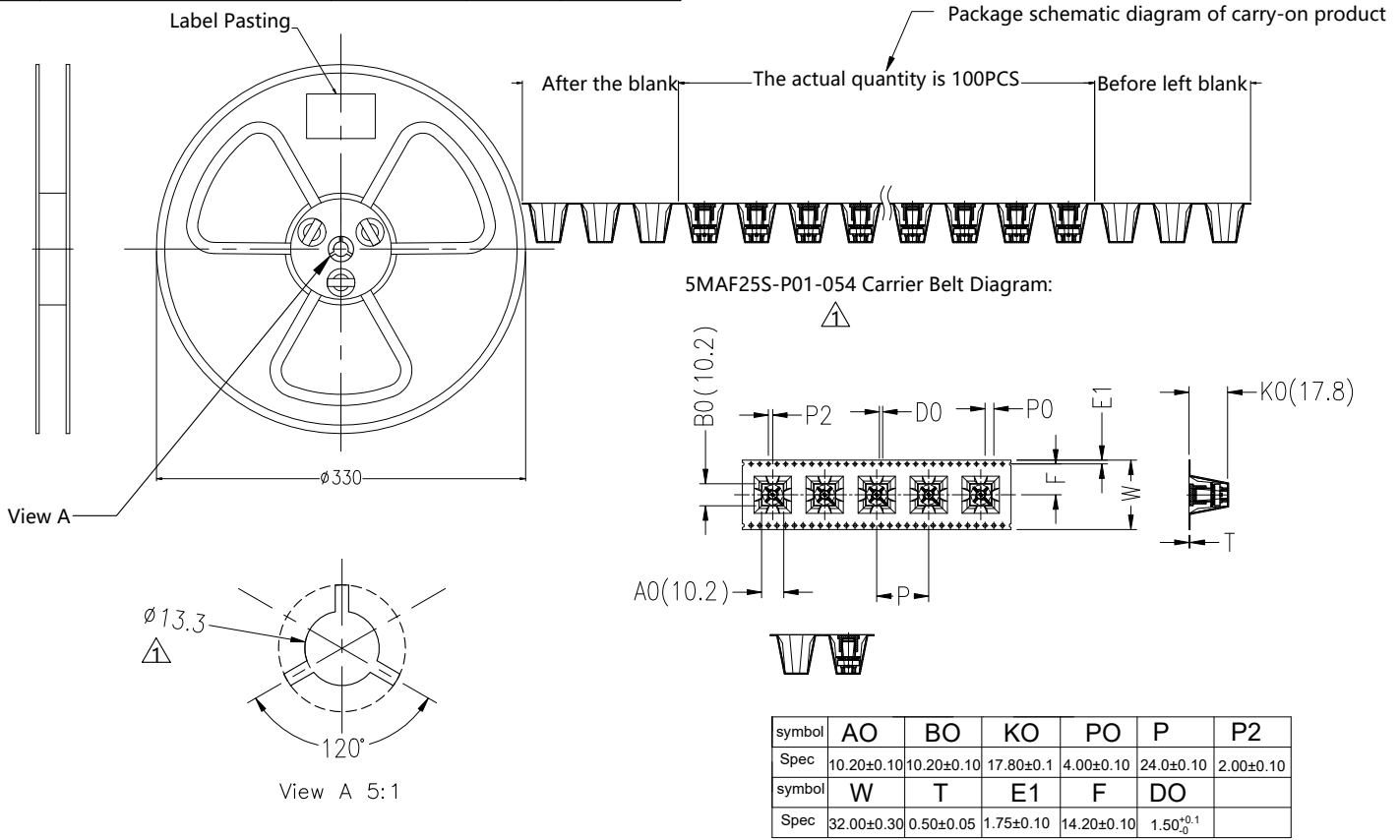

symbol	AO	BO	KO	PO	P	P2
Spec	10.20±0.10	10.20±0.10	17.80±0.1	4.00±0.10	24.0±0.10	2.00±0.10
symbol	W	T	E1	F	DO	
Spec	32.00±0.30	0.50±0.05	1.75±0.10	14.20±0.10	1.50 ^{+0.1} ₀	

MATERIALS AND PLATING		UNIT: MICRO-INCHES
PART NAME	MATERIALS	PLATING
BODY	BRASS C3604	GOLD 3μ " / NICKEL/COPPER
INSULATOR	PTFE ASTM-D-1710	N/A
CONTACT PIN	BERYLLIUM COPPER	GOLD 10μ " / NICKEL/COPPER
WASHER	STAINLESS STEEL	PASSIVATE

ELECTRICAL CHARACTERISTICS	
IMPEDANCE	50 Ω
VOLTAGE RATING	335 V(rms)
FREQUENCY RANGE	DC ~ 6 GHz
DIELECTRIC WITHSTANDING VOLTAGE	> 500 V
CONTACT RESISTANCE	CENTER CONTACT
	OUTER CONTACT
INSULATION RESISTANCE	> 5000 MΩ
INSERTION LOSS	N/A
VSWR	< 1.15 @ DC~6 GHz
3RD INTERMODULATION	N/A

MECHANICAL CHARACTERISTICS	
FORCE TO ENGAGE AND DISENGAGE	N/A
CENTER CONTACT RETENTION FORCE	> 6 lbs
RECOMMENDED COUPLING TORQUE	N/A
COUPLING NUT RETENTION FORCE	N/A
DURABILITY	> 500cycles

ENVIRONMENTAL PARAMETER	
TEMPERATURE RANGE	-55 °C~+125 °C

* CUSTOMER OUTLINE DRAWING

UNLESS OTHERWISE SPECIFIED:
 1) EDGES : C0.15 MAX ;
 2) REMOVE ALL BURRS ;
 3) SURFACE ROUGHNESS : Ra1.6 ;
 4) UNITS : mm ;
 5) DIMENSIONS TOLERANCES
 DECIMALS : .x ±0.3 .xx ±0.2 .xxx±0.1;
 ANGLES : ± 5°.

THIRD ANGLE PROJECTION 	
APPROVED :	CUSTOMER P/N :
CHECKED :	SCALE : 1 : 1
DRAWING :	DATE : 2021-09-08
PAGE : 1/1	



TITLE : SMA FEMALE S/T FOR PCB SMT,50Ω

DRAWING NO. : 5MAF25S-P01-054

COMPANY WEBSITE : www.slkcorp.com