

REV.	DESCRIPTION	ECN NO.	NAME	DATE	 ALL PARTS MUST MEET TO RoHS REQUIREMENTS
1	NEW FRAME	N/A	JING	2020-06-20	

REMARKS:

1. CRIMPED FERRULE  
HEX. CRIMP SIZE .130"
2. CONTACT PIN TO SOLDER

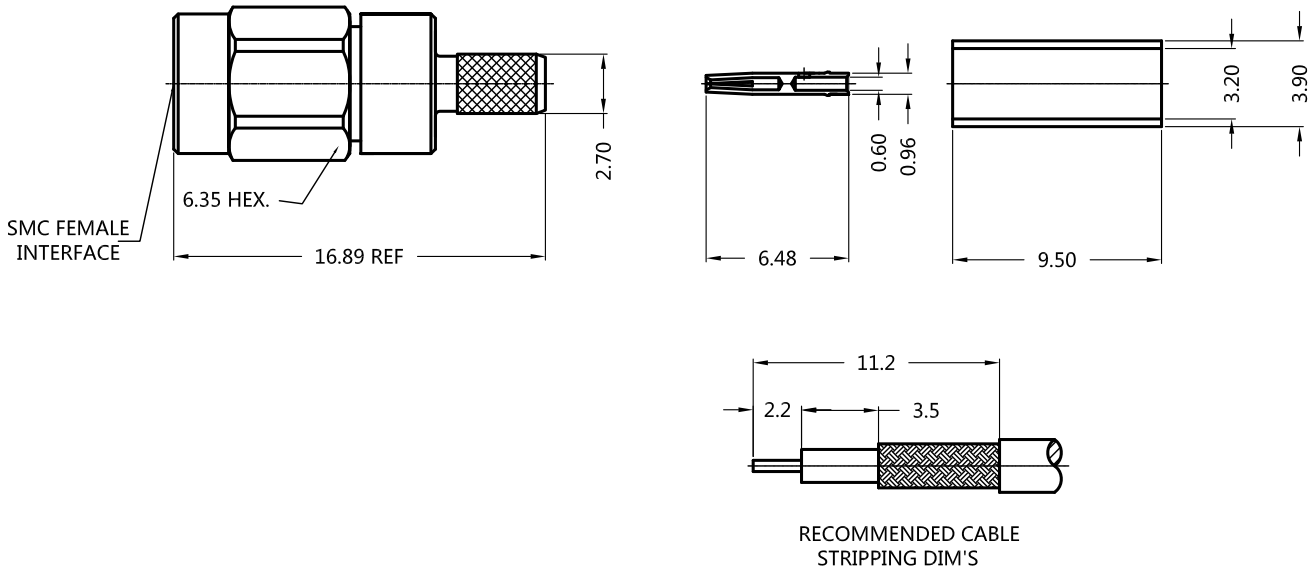

MATERIALS AND PLATING		UNIT: MICRO-INCHES
PART NAME	MATERIALS	PLATING
BODY	BRASS C3604	GOLD 3u"/ NICKEL
INSULATOR	TEFLON MIL-P-19468	N/A
CONTACT PIN	PHOSPHOR BRONZE	GOLD 5u"/COPPER
FERRULE	BRASS	GOLD 3u"/ NICKEL

ELECTRICAL CHARACTERISTICS	
IMPEDANCE	50 Ω
VOLTAGE RATING	500 V(rms)
FREQUENCY RANGE	0 ~ 3 GHz
DIELECTRIC WITHSTANDING VOLTAGE	>500 V
CONTACT RESISTANCE	CENTER CONTACT
	OUTER CONTACT
INSULATION RESISTANCE	>1000 MΩ
INSERTION LOSS	According as the cable
RF-LEAKAGE	N/A
VSWR	<1.35 @ 3 GHz
3RD INTERMODULATION	N/A

MECHANICAL CHARACTERISTICS	
FORCE TO ENGAGE AND DISENGAGE	N/A
CENTER CONTACT RETENTION FORCE	N/A
RECOMMENDED COUPLING TORQUE	7-10 in-lbs
COUPLING NUT RETENTION FORCE	60 lbs MIN.
DURABILITY	>500 cycles

ENVIRONMENTAL PARAMETER	
TEMPERATURE RANGE	-55 °C~+155 °C
VIBRATION	MIL- STD 202, Meth. 204,Cond. C
SHOCK	MIL- STD 202, Meth. 213,Cond. C

\* CUSTOMER OUTLINE DRAWING

UNLESS OTHERWISE SPECIFIED:

- 1) EDGES : C0.15 MAX ;
- 2) REMOVE ALL BURRS ;
- 3) SURFACE ROUGHNESS : Ra1.6 ;
- 4) UNITS : mm ;
- 5) DIMENSIONS TOLERANCES  
DECIMALS : .x ±0.3 .xx ±0.2 .xxx±0.1;  
ANGLES : ± 5°.

THIRD ANGLE PROJECTION

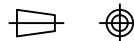

APPROVED :

CUSTOMER P/N :

CHECKED :

SCALE :

3 : 1

DRAWING :

JING

DATE : 2020-06-20

PAGE : 1/1



TITLE : SMC ST FEMALE FOR  
RG-316/U, RG174/U CABLE

DRAWING NO. :

5AMM11S-A02

COMPANY WEBSITE : www.slkcorp.com

CUSTOMER OUTLINE DRAWING