

REV.	DESCRIPTION	ECN NO.	NAME	DATE	 ALL PARTS MUST MEET TO RoHS REQUIREMENTS
0	FIRST EDITION	N/A	Liu	2022-05-27	

REMARKS:
 1. CONTACT PIN TO SOLDER
 2. CRIMPED FERRULE HEX. CRIMP SIZE .213"

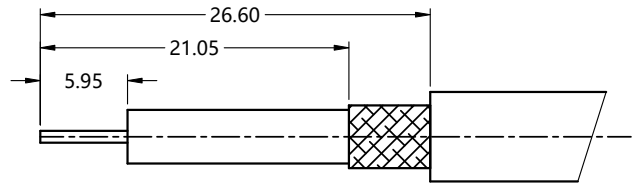

RECOMMENDED CABLE STRIPPING DIM'S

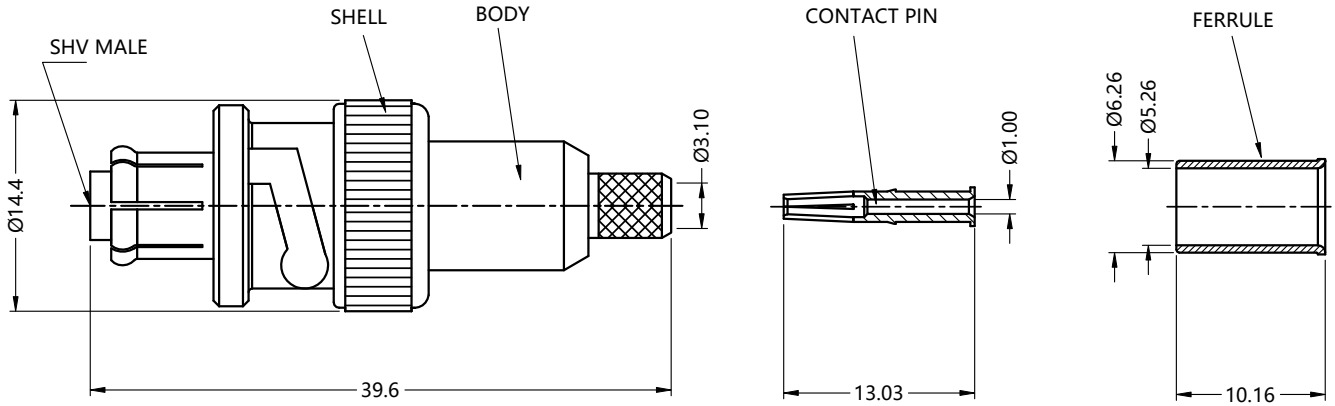

MATERIALS AND PLATING		UNIT: MICRO-INCHES
PART NAME	MATERIALS	PLATING
BODY/SHELL	BRASS	NICKEL 100u"/COPPER
INSULATOR	PTFE ASTM-D-1710	N/A
CONTACT PIN	BERYLLIUM COPPER	GOLD 50u"/NICKEL/COPPER
FERRULE	BRASS	TIN 100u"/COPPER

ELECTRICAL CHARACTERISTICS	
IMPEDANCE	50Ω
VOLTAGE RATING	3500 V(rms)
FREQUENCY RANGE	DC ~ 300 MHz
DIELECTRIC WITHSTANDING VOLTAGE	DC > 5000 V RMS
CONTACT RESISTANCE	CENTER CONTACT
	OUTER CONTACT
INSULATION RESISTANCE	> 5000 MΩ
INSERTION LOSS	N/A
VSWR	< 1.30
3RD INTERMODULATION	N/A

MECHANICAL CHARACTERISTICS	
FORCE TO ENGAGE AND DISENGAGE	N/A
CENTER CONTACT RETENTION FORCE	N/A
RECOMMENDED COUPLING TORQUE	0.6~2.5 in-ibs
COUPLING NUT RETENTION FORCE	> 101 lbs
DURABILITY	> 500 cycles

ENVIRONMENTAL PARAMETER	
TEMPERATURE RANGE	-40°C ~ +165 °C
CORROSION	MIL- STD 202, Meth. 101, Cond. B
VIBRATION	MIL- STD 202, Meth. 204, Cond. A
SHOCK	MIL- STD 202, Meth. 213, Cond. I

* CUSTOMER OUTLINE DRAWING

UNLESS OTHERWISE SPECIFIED:
 1) EDGES : C0.15 MAX ;
 2) REMOVE ALL BURRS ;
 3) SURFACE ROUGHNESS : Ra1.6 ;
 4) UNITS : mm ;
 5) DIMENSIONS TOLERANCES
 DECIMALS : .x ±0.3 .xx ±0.2 .xxx±0.1;
 ANGLES : ± 5°.

THIRD ANGLE PROJECTION

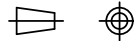

APPROVED :

CUSTOMER P/N :

CHECKED :

SCALE :

1 : 1

DRAWING :

DATE : 2022-05-27

PAGE : 1/1



TITLE : SHV MALE S/T CRIMP FOR RG-58 CABLE, 50Ω

DRAWING NO. : 5SHM11S-A41-001

COMPANY WEBSITE : www.slkcorp.com