

REV.	DESCRIPTION	ECN NO.	NAME	DATE
0	FIRST EDITION	N/A	YWD	2022-01-13

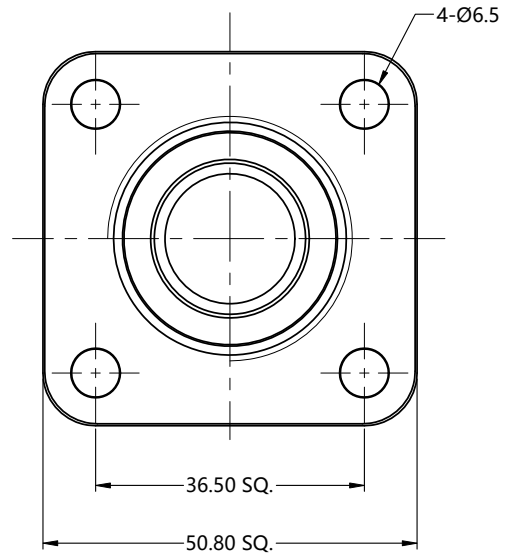

ALL PARTS MUST MEET TO RoHS REQUIREMENTS

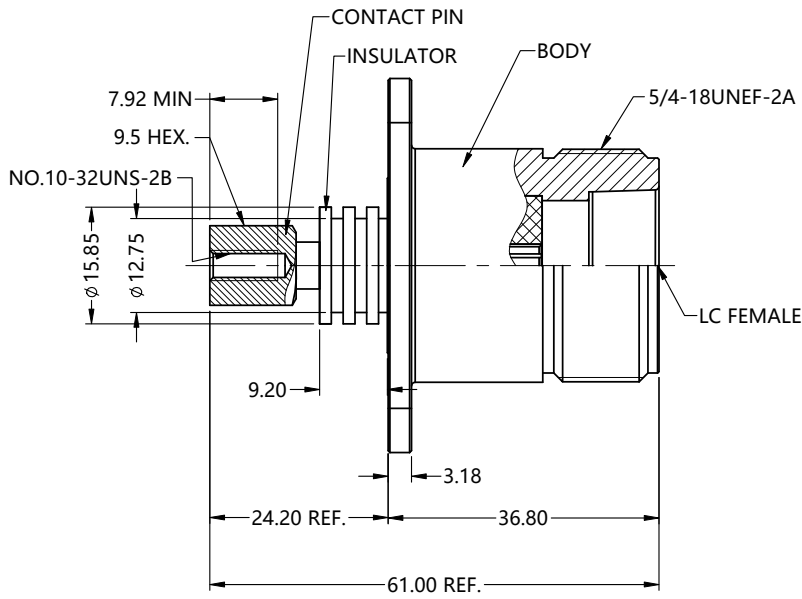

MATERIALS AND PLATING		UNIT: MICRO-INCHES
PART NAME	MATERIALS	PLATING
BODY	BRASS C3604	NICKEL 100 u"/COPPER
CONTACT PIN	BE-CU C17300	SILVER 200 u"/COPPER
INSULATOR	PTFE ASTM-D-1710	N/A
RING	BRASS C3604	NICKEL 100 u"/COPPER

ELECTRICAL CHARACTERISTICS	
IMPEDANCE	50 Ω
VOLTAGE RATING	N/A
FREQUENCY RANGE	DC~2.5 GHz
DIELECTRIC WITHSTANDING VOLTAGE	>5000 V
CONTACT RESISTANCE	CENTER CONTACT
	OUTER CONTACT
INSULATION RESISTANCE	>10000 MΩ
INSERTION LOSS	N/A
RETURN LOSS	N/A
VSWR	N/A
3RD INTERMODULATION	N/A

MECHANICAL CHARACTERISTICS	
FORCE TO ENGAGE AND DISENGAGE	N/A
CENTER CONTACT RETENTION FORCE	>20 lbs
RECOMMENDED COUPLING TORQUE	N/A
CABLE RETENTION FORCE	N/A
DURABILITY	>500 cycles

ENVIRONMENTAL PARAMETER	
TEMPERATURE RANGE	-45 °C~+125 °C

**\* CUSTOMER OUTLINE DRAWING**

UNLESS OTHERWISE SPECIFIED:  
 1) EDGES : C0.15 MAX ;  
 2) REMOVE ALL BURRS ;  
 3) SURFACE ROUGHNESS : Ra1.6 ;  
 4) UNITS : mm ;  
 5) DIMENSIONS TOLERANCES  
 DECIMALS : .x ±0.3 .xx ±0.2 .xxx±0.1;  
 ANGLES : ± 5°.

THIRD ANGLE PROJECTION

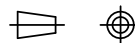

APPROVED :

CUSTOMER P/N :

CHECKED :

SCALE :

1: 1

DRAWING :

DATE : 2022-01-13

PAGE : 1/1



TITLE : LC Female to Female  
Terminal #10-32 with 4 Holes Flange,50Q

DRAWING NO. :

5EZ006S-LCF-003

COMPANY WEBSITE : www.slkcorp.com

CUSTOMER OUTLINE DRAWING