

| REV. | DESCRIPTION   | ECN NO. | NAME | DATE       |
|------|---------------|---------|------|------------|
| 0    | FIRST EDITION | N/A     | Liu  | 2022-09-07 |

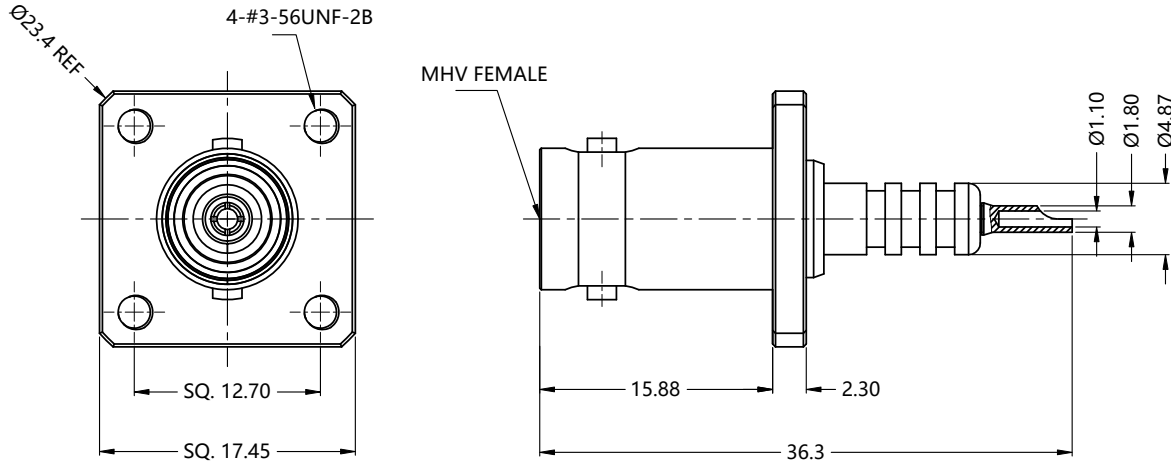

ALL PARTS MUST MEET TO RoHS REQUIREMENTS



| MATERIALS AND PLATING |                  | UNIT: MICRO-INCHES     |
|-----------------------|------------------|------------------------|
| PART NAME             | MATERIALS        | PLATING                |
| BODY                  | BRASS            | ALBALOY 100 u" /COPPER |
| INSULATOR             | PTFE ASTM-D-1710 | N/A                    |
| CONTACT PIN           | BERYLLIUM COPPER | SILVER 120 u"/COPPER   |

| ELECTRICAL CHARACTERISTICS      |                |
|---------------------------------|----------------|
| IMPEDANCE                       | 50 Ω           |
| VOLTAGE RATING                  | 1600 V(rms)    |
| FREQUENCY RANGE                 | DC ~ 300 MHz   |
| DIELECTRIC WITHSTANDING VOLTAGE | > 5000 V       |
| CONTACT RESISTANCE              | CENTER CONTACT |
|                                 | OUTER CONTACT  |
| INSULATION RESISTANCE           | > 5 GΩ         |
| INSERTION LOSS                  | N/A            |
| RF-LEAKAGE                      | N/A            |
| VSWR                            | N/A            |
| 3RD INTERMODULATION             | N/A            |

| MECHANICAL CHARACTERISTICS     |              |
|--------------------------------|--------------|
| FORCE TO ENGAGE AND DISENGAGE  | N/A          |
| CENTER CONTACT RETENTION FORCE | > 6.1 lbs    |
| RECOMMENDED COUPLING TORQUE    | N/A          |
| COUPLING NUT RETENTION FORCE   | N/A          |
| DURABILITY                     | > 500 cycles |

| ENVIRONMENTAL PARAMETER |                  |
|-------------------------|------------------|
| TEMPERATURE RANGE       | -65 °C ~ +165 °C |

**\* CUSTOMER OUTLINE DRAWING**

UNLESS OTHERWISE SPECIFIED:  
 1) EDGES : C0.15 MAX ;  
 2) REMOVE ALL BURRS ;  
 3) SURFACE ROUGHNESS : Ra1.6 ;  
 4) UNITS : mm ;  
 5) DIMENSIONS TOLERANCES  
 DECIMALS : .x ±0.3 .xx ±0.2 .xxx±0.1;  
 ANGLES : ± 5°.

THIRD ANGLE PROJECTION

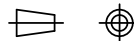

APPROVED :

CUSTOMER P/N :

CHECKED :

SCALE :

2: 1

DRAWING :

DATE : 2022-09-07

PAGE : 1/1



TITLE : MHV FEMALE CONNECTOR SOLDER ATTACHMENT 4 HOLE FLANGE MOUNT SOLDER CUP TERMINAL

DRAWING NO. :

5MVF85S-H41

COMPANY WEBSITE : www.slkcorp.com

CUSTOMER OUTLINE DRAWING