

REV.	DESCRIPTION	ECN NO.	NAME	DATE
1	NEW FRAME	N/A	LDH	2020-9-1



ALL PARTS MUST MEET TO RoHS REQUIREMENTS

REMARKS:

1. ADDS SIZE: 13.07mm
2. CONTACT PIN TO CAPTIVE
3. FERRULE TO SOLDER

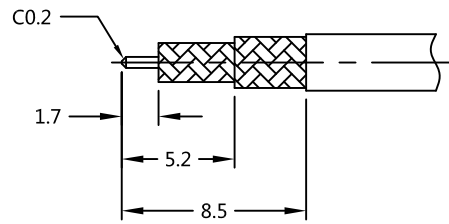

RECOMMENDED CABLE STRIPPING DIM'S

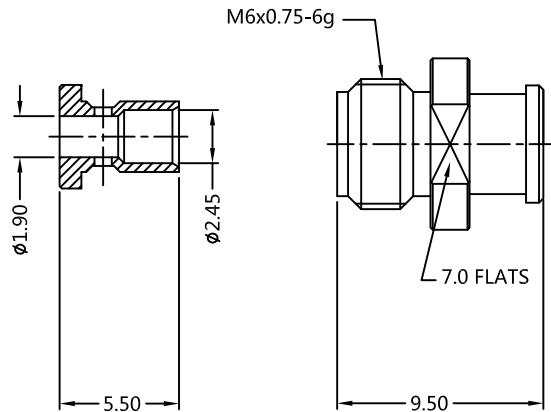
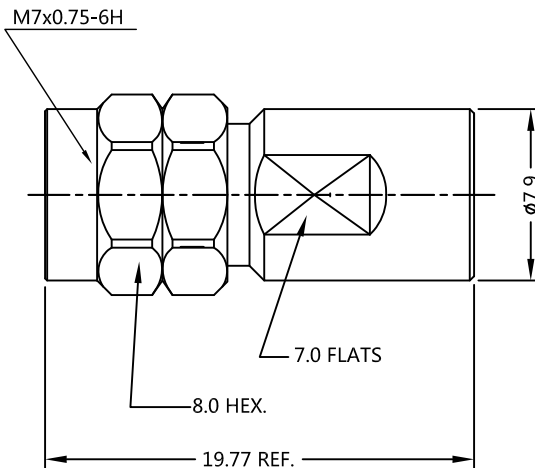

MATERIALS AND PLATING		UNIT: MICRO-INCHES
PART NAME	MATERIALS	PLATING
SHELL/BARREL	STAINLESS STEEL	PASSIVATION
CONTACT PIN	Be-Cu C17300	GOLD 50u"/COPPER
INSULATOR	PEEK	N/A
BODY	STAINLESS STEEL	PASSIVATION
FERRULE	BRASS C3604	GOLD 10u"/NICKEL/COPPER

ELECTRICAL CHARACTERISTICS	
IMPEDANCE	50 Ω
VOLTAGE RATING	335 V(rms)
FREQUENCY RANGE	0 ~ 67 GHz
DIELECTRIC WITHSTANDING VOLTAGE	500 V
CONTACT RESISTANCE	CENTER CONTACT <3.0 mΩ
	OUTER CONTACT <2.0 mΩ
INSULATION RESISTANCE	>5000 MΩ
INSERTION LOSS	ACCORDING AS THE CABLE
VSWR	<1.10 @0-18 GHz / <1.20 @18-50 GHz <1.30 @50-67 GHz
3RD INTERMODULATION	N/A

MECHANICAL CHARACTERISTICS	
FORCE TO ENGAGE AND DISENGAGE	N/A
CENTER CONTACT RETENTION FORCE	>6 lbs
COUPLING PROOF TORQUE	8-10 in-lbs
COUPLING NUT RETENTION FORCE	>60 lbs
DURABILITY	>500 cycles

ENVIRONMENTAL PARAMETER	
TEMPERATURE RANGE	-55 °C ~ +125 °C
CORROSION	US MIL- STD 202, METH. 101, COND. B
VIBRATION	US MIL- STD 202, METH. 204, COND. D
SHOCK	US MIL- STD 202, METH. 213, COND. I

\* CUSTOMER OUTLINE DRAWING

UNLESS OTHERWISE SPECIFIED:

- 1) EDGES : C0.15 MAX ;
- 2) REMOVE ALL BURRS ;
- 3) SURFACE ROUGHNESS : Ra1.6 ;
- 4) UNITS : mm ;
- 5) DIMENSIONS TOLERANCES  
 DECIMALS : .x ±0.3 .xx ±0.2 .xxx±0.1;  
 ANGLES : ± 5°.

THIRD ANGLE PROJECTION

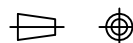

APPROVED :

CUSTOMER P/N :

CHECKED :

SCALE :

3 : 1

DRAWING :

LDH

DATE : 2020-9-1

PAGE : 1/1



TITLE : 1.85mm MALE S/T FOR SLB-230-P CABLE,50Ω

DRAWING NO. : 5P1M15S-A564-002

COMPANY WEBSITE : www.slkcorp.com

CUSTOMER OUTLINE DRAWING