

| REV | DESCRIPTION | ECN NO | NAME | DATE |
|-----|-------------------|--------|-------|------------|
| 1 | Modify dimensions | N/A | Flame | 2014-06-24 |
| 2 | NEW FRAME | N/A | LW | 2020-07-15 |

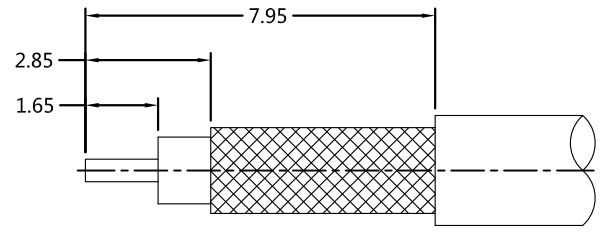

ALL PARTS MUST MEET TO RoHS REQUIREMENTS

REMARKS:
1. CRIMPED FERRULE HEX. CRIMP SIZE .129"
2. CENTER CONTACT TO SOLDER



RECOMMENDED CABLE STRIPPING DIM'S

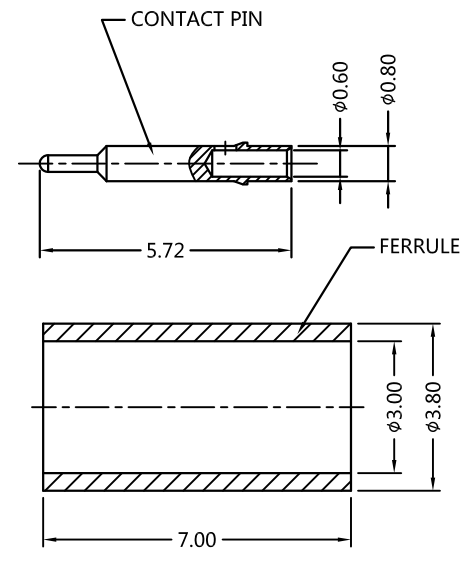
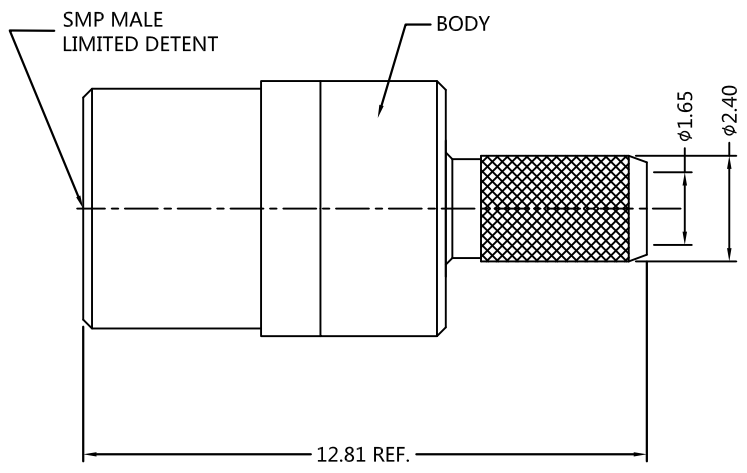

| MATERIALS AND PLATING | | UNIT: MICRO-INCHES |
|-----------------------|------------------|-------------------------|
| BODY | BRASS | GOLD 3 u"/NICKEL/COPPER |
| CONTACT PIN | BERYLLIUM COPPER | GOLD 5 u"/NICKEL/COPPER |
| INSULATOR | PTFE ASTM-D-1710 | N/A |
| FERRULE | BRASS | GOLD 3 u"/NICKEL/COPPER |

| ELECTRICAL CHARACTERISTICS | | |
|---------------------------------|----------------|---------|
| IMPEDANCE | 50 Ω | |
| VOLTAGE RATING | 175 V(rms) | |
| FREQUENCY RANGE | 0~6 GHz | |
| DIELECTRIC WITHSTANDING VOLTAGE | >500 V | |
| CONTACT RESISTANCE | CENTER CONTACT | <6.0 mΩ |
| | OUTER CONTACT | <3.0 mΩ |
| INSULATION RESISTANCE | >5000 MΩ | |
| INSERTION LOSS | <0.1v/F dB | |
| VSWR | <1.30 | |
| 3RD INTERMODULATION | N/A | |

| MECHANICAL CHARACTERISTICS | |
|--------------------------------|--------------------------|
| CENTER CONTACT RETENTION FORCE | N/A |
| FORCE TO ENGAGE AND DISENGAGE | <10 lbs (ENGAGE FORCE) |
| | >2 lbs (DISENGAGE FORCE) |
| DURABILITY | >500 cycles |

| ENVIRONMENTAL CHARACTERISTICS | |
|-------------------------------|---------------------------------|
| TEMPERATURE RANGE | -40 °C~+165 °C |
| THERMAL SHOCK | MIL- STD 202, Meth. 107,Cond. B |
| VIBRATION | MIL- STD 202, Meth. 204,Cond. D |
| SHOCK | MIL- STD 202, Meth. 213,Cond. I |

* CUSTOMER OUTLINE DRAWING

UNLESS OTHERWISE SPECIFIED:
1) C0.15 MAX;
2) REMOVE ALL BURRS;
3) SURFACE ROUGHNESS : Ra1.6;
4) UNITS:mm;
5) DIMENSIONS TOLERANCES
DECIMALS .x ±0.3 .xx ±0.2 .xxx±0.1
ANGLES ±5°

| | |
|----------------------------------|------------------|
| THIRD ANGLE PROJECTION | |
| APPROVED: | CUSTOMER P/N: |
| CHECKED: | SCALE: |
| DRAWING: | DATE: 2020-07-15 |
| COMPANY WEBSITE: www.slkcorp.com | |

TITLE: SMP MALE S/T CRIMP FOR RG-316 CABLE,50Ω
DRAWING NO: 5SPM11S-A02

CUSTOMER OUTLINE DRAWING