

REV.	DESCRIPTION	ECN NO.	NAME	DATE	 ALL PARTS MUST MEET TO RoHS REQUIREMENTS
0	FIRST EDITION	N/A	Xu	16/03/10	
0-1	MODIFY THE STRUCTURE	N/A	Xu	16/03/15	
2	REPLACE FRAME	N/A	Kevin.Li	2020-07-13	

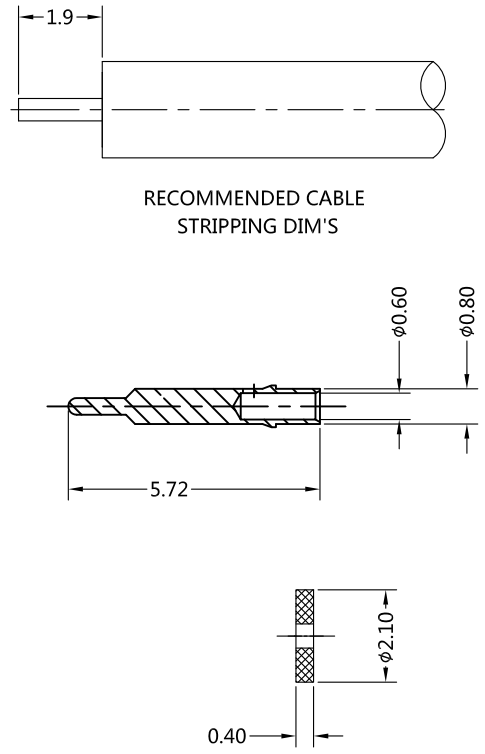
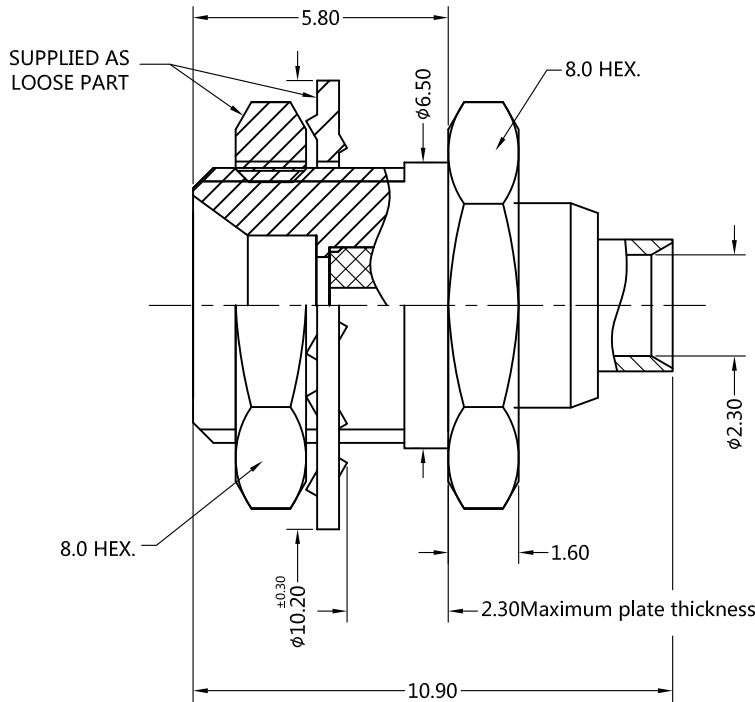

MATERIALS AND PLATING		UNIT: MICRO-INCHES
PART NAME	MATERIALS	PLATING
BODY	BRASS	GOLD 3 u" / NICKEL / COPPER
INSULATOR	PTFE ASTM-D-1710	N/A
CONTACT PIN	BERYLLIUM COPPER	GOLD 5 u"/NICKEL/COPPER

ELECTRICAL CHARACTERISTICS	
IMPEDANCE	50 Ω
VOLTAGE RATING	335V(rms)
FREQUENCY RANGE	0 ~ 6 GHz
DIELECTRIC WITHSTANDING VOLTAGE	> 500 V
CONTACT RESISTANCE	CENTER CONTACT
	OUTER CONTACT
INSULATION RESISTANCE	> 1000MΩ
INSERTION LOSS	> 0.2dB@0~6GHz
VSWR	< 1.3
3RD INTERMODULATION	N/A

MECHANICAL CHARACTERISTICS	
FORCE TO ENGAGE AND DISENGAGE	N/A
CENTER CONTACT RETENTION FORCE	> 1.5 lbs
DURABILITY	> 500cycles

ENVIRONMENTAL PARAMETER	
TEMPERATURE RANGE	-40 °C ~ +165 °C
VIBRATION	US MIL- STD 202, Meth. 204,Cond. D
SHOCK	US MIL- STD 202, Meth. 213,Cond. I
CORROSION	US MIL- STD 202, Meth. 101,Cond. B

*** CUSTOMER OUTLINE DRAWING**

UNLESS OTHERWISE SPECIFIED:
 1) EDGES : C0.15 MAX ;
 2) REMOVE ALL BURRS ;
 3) SURFACE ROUGHNESS : Ra1.6 ;
 4) UNITS : mm ;
 5) DIMENSIONS TOLERANCES
 DECIMALS : .x ±0.3 .xx ±0.2 .xxx±0.1;
 ANGLES : ± 5°.

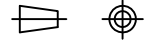
THIRD ANGLE PROJECTION		
APPROVED :	CUSTOMER P/N :	
CHECKED :	SCALE :	
DRAWING :	DATE : 2020-07-13	
PAGE : 1/1		



TITLE : SMP MALE ST SOLDER FOR RG405 CABLE ,BULKHEAD-FRONT MOUNT,50Ω
 DRAWING NO. : 5SPM35S-A82
 COMPANY WEBSITE : www.slkcorp.com

CUSTOMER OUTLINE DRAWING