

REV.	DESCRIPTION	ECN NO.	NAME	DATE	 ALL PARTS MUST MEET TO RoHS REQUIREMENTS
0	FIRST EDITION	N/A	WYJ	2015-10-21	
1	NEW FRAME	N/A	Liu	2020-09-27	

REMARKS:
 1. ADDS SIZE:6.5mm
 2. CONTACT PIN TO CAPTIVE
 3. FERRULE TO SOLDER

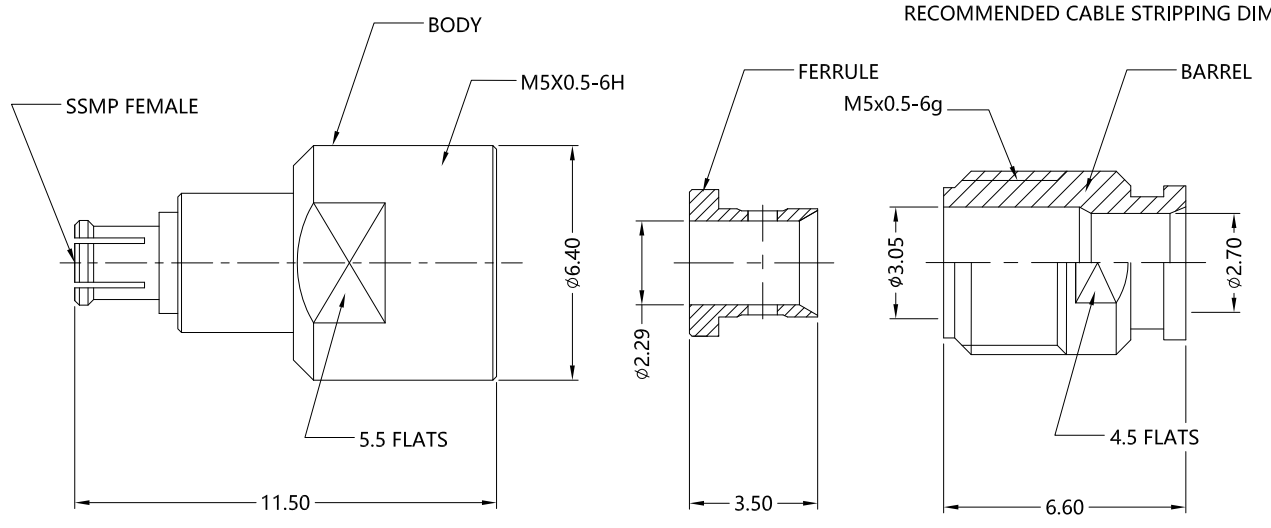
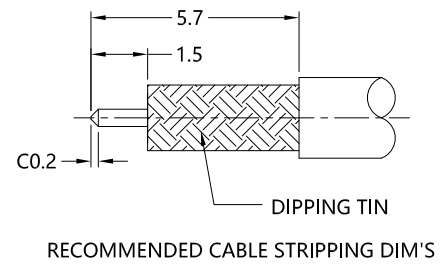

MATERIALS AND PLATING		UNIT: MICRO-INCHES
PART NAME	MATERIALS	PLATING
BODY	Be-Cu C17300	GOLD 30 u"/NICKEL/COPPER
CONTACT PIN	Be-Cu C17300	GOLD 50 u"/NICKEL/COPPER
INSULATOR	PEEK	N/A
FERRULE	BRASS C3604	GOLD 30 u"/NICKEL/COPPER
BARREL	STAINLESS STEEL	PASSIVATION

ELECTRICAL CHARACTERISTICS	
IMPEDANCE	50 Ω
VOLTAGE RATING	335 V(rms)
FREQUENCY RANGE	0 ~ 40 GHz
DIELECTRIC WITHSTANDING VOLTAGE	>500 V
CONTACT RESISTANCE	CENTER CONTACT
	OUTER CONTACT
INSULATION RESISTANCE	>1000 MΩ
INSERTION LOSS	$<0.1x\sqrt{F(\text{GHz})}$ dB
VSWR	<1.5
3RD INTERMODULATION	N/A

MECHANICAL CHARACTERISTICS		
CENTER CONTACT RETENTION FORCE		>3 lbs
Engagement force	Full detent	<4.5 lbs
	Smooth bore	<2.5 lbs
Disengagement force	Full detent	<6.5 lbs
	Smooth bore	<1.5 lbs
DURABILITY	Full detent	>100 cycles
	Smooth bore	>500 cycles

ENVIRONMENTAL PARAMETER	
TEMPERATURE RANGE	-40 °C ~ +125 °C

*** CUSTOMER OUTLINE DRAWING**

UNLESS OTHERWISE SPECIFIED:
 1) EDGES : C0.15 MAX ;
 2) REMOVE ALL BURRS ;
 3) SURFACE ROUGHNESS : Ra1.6 ;
 4) UNITS : mm ;
 5) DIMENSIONS TOLERANCES
 DECIMALS : .x ±0.3 .xx ±0.2 .xxx±0.1;
 ANGLES : ± 5°.

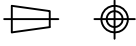
THIRD ANGLE PROJECTION		
APPROVED :	CUSTOMER P/N :	
CHECKED :	SCALE :	
DRAWING :	DATE :	
PAGE : 1/1		



TITLE : SSMP FEMALE S/T CLAMP FOR Tflex-405 CABLE,50Ω
 DRAWING NO. : 5MPF15S-A82-001
 COMPANY WEBSITE : www.slkcorp.com

CUSTOMER OUTLINE DRAWING