

REV.	DESCRIPTION	ECN NO.	NAME	DATE
1	NEW FRAME	N/A	HYH	2020-08-18

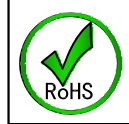

ALL PARTS MUST MEET TO RoHS REQUIREMENTS

REMARKS:
 1. CRIMPED FERRULE HEX. CRIMP SIZE .128"
 2. CONTACT PIN TO SOLDER

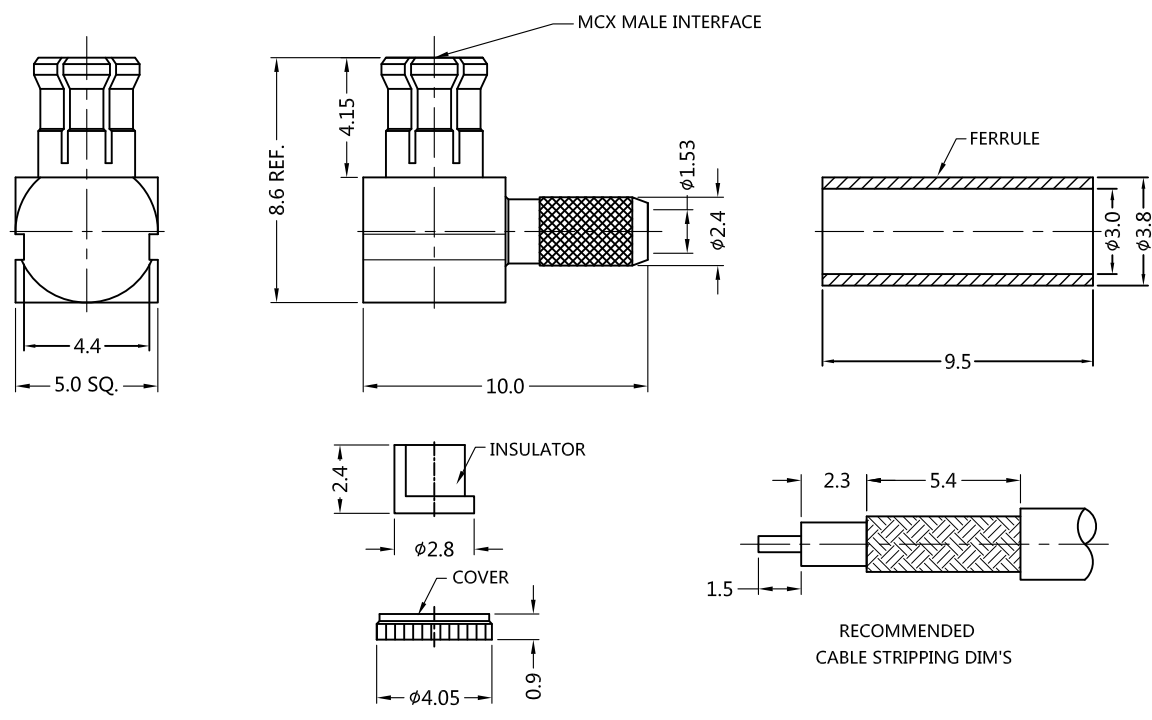

MATERIALS AND PLATING		UNIT: MICRO-INCHES
PART NAME	MATERIALS	PLATING
BODY	BRASS C3604	GOLD PL.10u"/NICKEL/COPPER
CONTACT PIN	BRASS C3604	GOLD PL.30u"/NICKEL/COPPER
INSULATOR	PTFE ASTM-D-1710	N/A
FERRULE	BRASS	GOLD PL.10u"/NICKEL/COPPER
COVER	BRASS C3604	GOLD PL.10u"/NICKEL/COPPER

ELECTRICAL CHARACTERISTICS	
IMPEDANCE	50 Ω
VOLTAGE RATING	170 V(rms)
FREQUENCY RANGE	DC ~ 6 GHz
DIELECTRIC WITHSTANDING VOLTAGE	>500 V
CONTACT RESISTANCE	CENTER CONTACT
	OUTER CONTACT
INSULATION RESISTANCE	>1000 MΩ
INSERTION LOSS	N/A
RETURN LOSS	N/A
VSWR	<1.3
3RD INTERMODULATION	N/A

MECHANICAL CHARACTERISTICS	
ENGAGEMENT FORCE	<14 lbs
SEPARATION FORCE	>1.8 lbs~4.5 lbs
CENTER CONTACT RETENTION FORCE	>2.25 lbs
CABLE RETENTION FORCE	N/A
DURABILITY	>500 cycles

ENVIRONMENTAL PARAMETER	
TEMPERATURE RANGE	-65 °C~+165 °C

CUSTOMER OUTLINE DRAWING

* CUSTOMER OUTLINE DRAWING

UNLESS OTHERWISE SPECIFIED:
 1) EDGES : C0.15 MAX ;
 2) REMOVE ALL BURRS ;
 3) SURFACE ROUGHNESS : Ra1.6 ;
 4) UNITS : mm ;
 5) DIMENSIONS TOLERANCES
 DECIMALS : .x ±0.3 .xx ±0.2 .xxx±0.1;
 ANGLES : ± 5°.

THIRD ANGLE PROJECTION		
APPROVED :	CUSTOMER P/N :	-
CHECKED :	SCALE :	1 : 1
DRAWING :	DATE :	2020-08-18
HYH	PAGE :	1/1

TITLE : MCX MALE R/A CRIMP FOR RG316 & RG174 CABLE,50Ω
 DRAWING NO. : 5MXM11R-A02-040
 COMPANY WEBSITE : www.slkcorp.com