

REV.	DESCRIPTION	ECN NO.	NAME	DATE
0-1	1500V WAS 500V	N/A	yy.ma	2015.03.12
0-2	Update washer plated	N/A	Flame	2015.03.12
3	NEW FRAME	N/A	HRWEI	2020-07-16

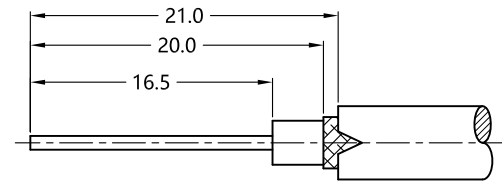

ALL PARTS MUST MEET TO RoHS REQUIREMENTS



RECOMMENDED CABLE STRIPPING DIM'S

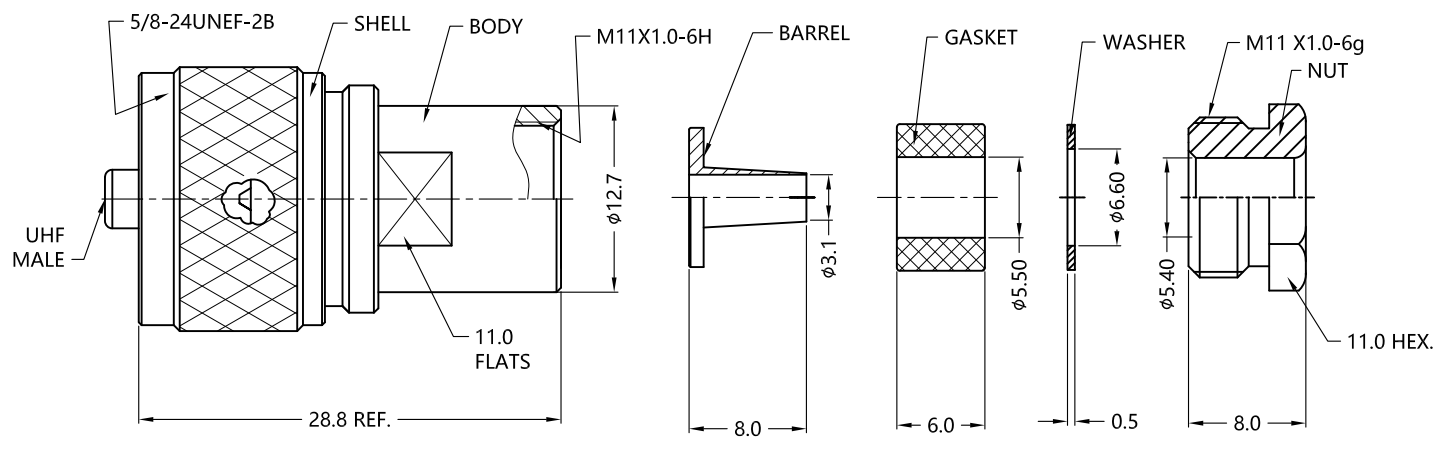

MATERIALS AND PLATING		UNIT: MICRO-INCHES
PART NAME	MATERIALS	PLATING
BODY/SHELL	BRASS C3604	SILVER 40 u"/COPPER
INSULATOR	TEFLON MIL-P-19468	N/A
CONTACT PIN	BRASS C3604	SILVER 40 u"/COPPER
GASKET	SILICONE	WHITE
BARREL	BRASS	SILVER 40 u"/COPPER
NUT/WASHER	BRASS C3604	SILVER 40 u"/COPPER

ELECTRICAL CHARACTERISTICS	
IMPEDANCE	50 Ω
VOLTAGE RATING	500 V(rms)
FREQUENCY RANGE	0 ~ 500 MHz
DIELECTRIC WITHSTANDING VOLTAGE	>1500 V
CONTACT RESISTANCE	CENTER CONTACT <3.0 mΩ
	OUTER CONTACT <2.0 mΩ
INSULATION RESISTANCE	>5000 MΩ
INSERTION LOSS	N/A
VSWR	N/A
3RD INTERMODULATION	N/A

MECHANICAL CHARACTERISTICS	
FORCE TO ENGAGE AND DISENGAGE	N/A
CABLE RETENTION FORCE	>170 N
RECOMMENDED COUPLING TORQUE	9-14 in-lbs
COUPLING NUT RETENTION FORCE	>100 lbs
DURABILITY	>500 cycles

ENVIRONMENTAL PARAMETER	
TEMPERATURE RANGE	-40 °C ~ +125 °C

\* CUSTOMER OUTLINE DRAWING

UNLESS OTHERWISE SPECIFIED:  
 1) EDGES : C0.15 MAX ;  
 2) REMOVE ALL BURRS ;  
 3) SURFACE ROUGHNESS : Ra1.6 ;  
 4) UNITS : mm ;  
 5) DIMENSIONS TOLERANCES  
 DECIMALS : .x ±0.3 .xx ±0.2 .xxx±0.1;  
 ANGLES : ± 5°.

THIRD ANGLE PROJECTION	
APPROVED :	CUSTOMER P/N :
CHECKED :	SCALE :
DRAWING :	DATE :
PAGE : 1/1	

TITLE : UHF MALE S/T CLAMP FOR RG58C/U CABLE,50Ω  
 DRAWING NO. : 5UCM14S-A41  
 COMPANY WEBSITE : www.slkcorp.com

CUSTOMER OUTLINE DRAWING