

| | | | | | |
|------|-----------------------|---------|-------|------------|---|
| REV. | DESCRIPTION | ECN NO. | NAME | DATE |  ALL PARTS MUST MEET TO RoHS REQUIREMENTS |
| 0-4 | ADD DETAIL PARTS SIZE | N/A | CLOUD | 2016-03-03 | |
| 5 | NEW FRAME | N/A | JING | 2020-07-27 | |

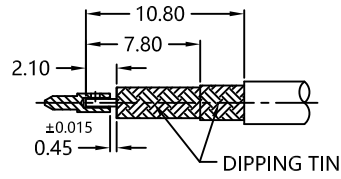

DIPPING TIN
RECOMMENDED CABLE STRIPPING DIM'S

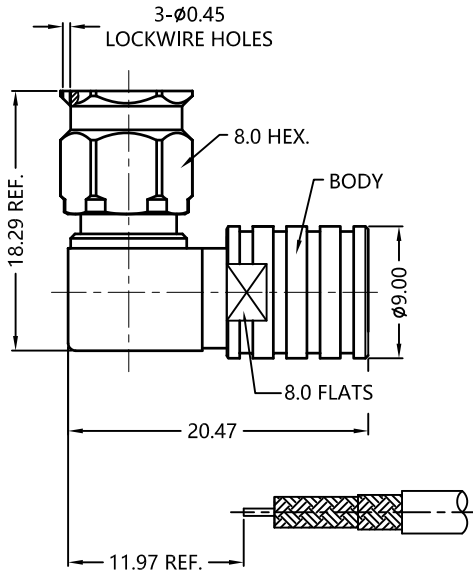

| MATERIALS AND PLATING | | UNIT: MICRO-INCHES |
|-----------------------|------------------|-------------------------|
| PART NAME | MATERIALS | PLATING |
| BODY | BRASS C3604 | GOLD 3u"/NICKEL/COPPER |
| INSULATOR | PTFE ASTM-D-1710 | N/A |
| CONTACT PIN | Be-Cu C17300 | GOLD 50u"/NICKEL/COPPER |
| GASKET | SILICONE | N/A |
| FERRULE | BRASS C3604 | GOLD 3u"/NICKEL/COPPER |
| BARREL | STAINLESS STEEL | PASSIVATION |

| ELECTRICAL CHARACTERISTICS | | |
|---------------------------------|------------------|---------|
| IMPEDANCE | 50 Ω | |
| VOLTAGE RATING | 335 V(rms) | |
| FREQUENCY RANGE | 0 ~ 18 GHz | |
| DIELECTRIC WITHSTANDING VOLTAGE | >500 V | |
| CONTACT RESISTANCE | CENTER CONTACT | <3.0 mΩ |
| | OUTER CONTACT | <2.0 mΩ |
| INSULATION RESISTANCE | >5000 MΩ | |
| INSERTION LOSS | <0.05x√F(GHz) dB | |
| RF-LEAKAGE | N/A | |
| VSWR | <1.35 @ 0~18 GHz | |
| 3RD INTERMODULATION | N/A | |

| MECHANICAL CHARACTERISTICS | |
|--------------------------------|-------------|
| FORCE TO ENGAGE AND DISENGAGE | N/A |
| CENTER CONTACT RETENTION FORCE | N/A |
| RECOMMENDED COUPLING TORQUE | 7-10 in-lbs |
| COUPLING NUT RETENTION FORCE | >60 lbs |
| DURABILITY | >500 cycles |

| ENVIRONMENTAL PARAMETER | |
|-------------------------|------------------|
| TEMPERATURE RANGE | -40 °C ~ +125 °C |

* CUSTOMER OUTLINE DRAWING

UNLESS OTHERWISE SPECIFIED:
 1) EDGES : C0.15 MAX ;
 2) REMOVE ALL BURRS ;
 3) SURFACE ROUGHNESS : Ra1.6 ;
 4) UNITS : mm ;
 5) DIMENSIONS TOLERANCES
 DECIMALS : .x ±0.3 .xx ±0.2 .xxx±0.1;
 ANGLES : ± 5°.

THIRD ANGLE PROJECTION

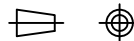

APPROVED :

CUSTOMER P/N :

CHECKED :

SCALE :

2: 1

DRAWING :

JING

DATE : 2020-07-27

PAGE : 1/1



TITLE : SMA MALE R/A SOLDER FOR SFT-316 CABLE

DRAWING NO. : 5MAM13R-A120

COMPANY WEBSITE : www.slkcorp.com

CUSTOMER OUTLINE DRAWING