

REV.	DESCRIPTION	ECN NO.	NAME	DATE
0	FIRST EDITION	N/A	yy.ma	2009-08-04
1	REPLACE FRAME	N/A	Kevin.Li	2020-07-11

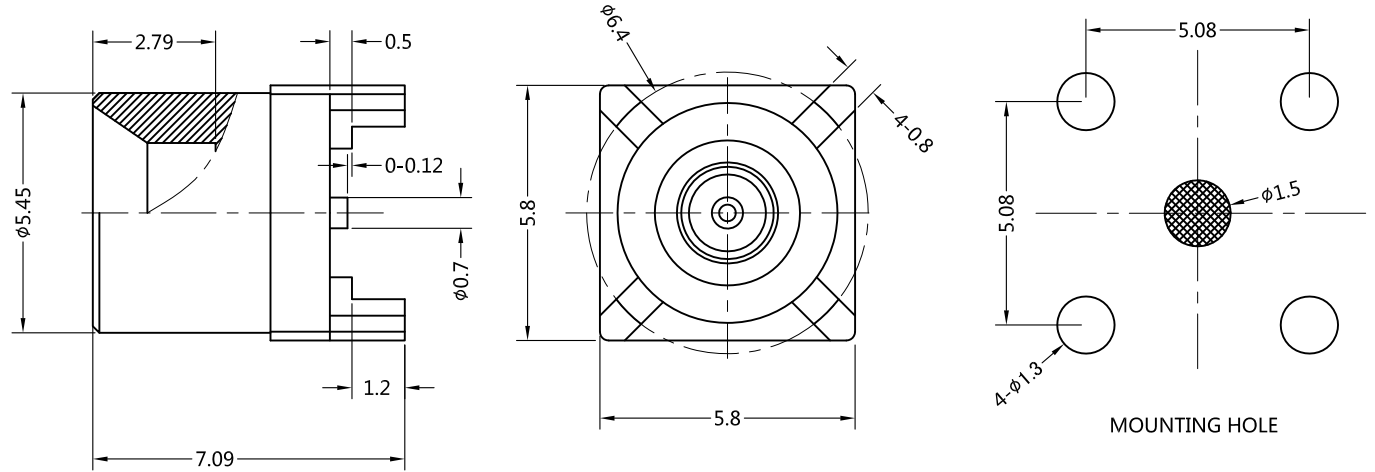

ALL PARTS MUST MEET TO RoHS REQUIREMENTS



MATERIALS AND PLATING		UNIT: MICRO-INCHES
PART NAME	MATERIALS	PLATING
BODY	BRASS	GOLD 20u" / NICKEL / COPPER
INSULATOR	PTFE ASTM-D-1710	N/A
CONTACT PIN	BERYLLIUM COPPER	GOLD 30 u"/NICKEL/COPPER

ELECTRICAL CHARACTERISTICS	
IMPEDANCE	50 Ω
VOLTAGE RATING	335V(rms)
FREQUENCY RANGE	DC-3 GHz
DIELECTRIC WITHSTANDING VOLTAGE	>500 V
CONTACT RESISTANCE	CENTER CONTACT
	OUTER CONTACT
INSULATION RESISTANCE	>5000MΩ
INSERTION LOSS	N/A
VSWR	<1.3
3RD INTERMODULATION	N/A

MECHANICAL CHARACTERISTICS	
FORCE TO ENGAGE AND DISENGAGE	N/A
RADIAL MISALIGNMENT	+0.25/-0.25mm
AXIAL MISALIGNMENT	0/+0.25mm
CENTER CONTACT RETENTION FORCE	> 1.5 lbs
DURABILITY	> 500cycles

ENVIRONMENTAL PARAMETER	
TEMPERATURE RANGE	-40 °C ~ +165 °C
VIBRATION	US MIL- STD 202, Meth. 204,Cond. D
SHOCK	US MIL- STD 202, Meth. 213,Cond. I
CORROSION	US MIL- STD 202, Meth. 101,Cond. B
RELATIVE HUMIDITY	MIL-STD-202,Method 106

*** CUSTOMER OUTLINE DRAWING**

UNLESS OTHERWISE SPECIFIED:
 1) EDGES : C0.15 MAX ;
 2) REMOVE ALL BURRS ;
 3) SURFACE ROUGHNESS : Ra1.6 ;
 4) UNITS : mm ;
 5) DIMENSIONS TOLERANCES
 DECIMALS : .x ±0.3 .xx ±0.2 .xxx±0.1;
 ANGLES : ± 5°.

THIRD ANGLE PROJECTION	
APPROVED :	CUSTOMER P/N :
CHECKED :	SCALE :
DRAWING :	DATE : 2020-07-11
PAGE : 1/1	

TITLE : SMP MALE S/T(SMOOTH BORE) FOR PCB THROUGH HOLE ,50Ω
 DRAWING NO. : 5SPM25S-P41-007
 COMPANY WEBSITE : www.slkcorp.com

CUSTOMER OUTLINE DRAWING