

REV.	DESCRIPTION	ECN NO.	NAME	DATE	 ALL PARTS MUST MEET TO RoHS REQUIREMENTS
A0	FIRST EDITION	N/A	WANG	2017-08-01	
A1	UPDATE DRAWING	N/A	JASON	2020-05-23	

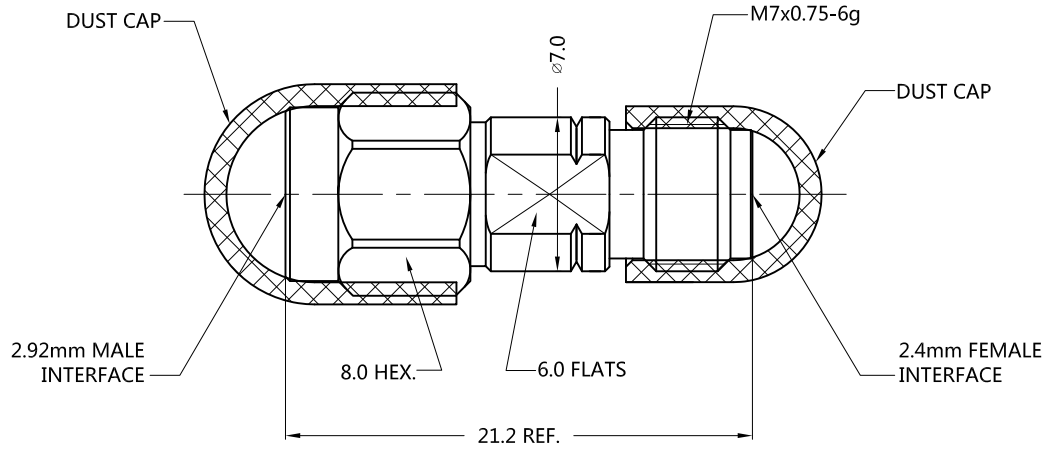

MATERIALS AND PLATING		UNIT: MICRO-INCHES
PART NAME	MATERIALS	PLATING
BODY/SHELL	STAINLESS STEEL	PASSIVATION
CONTACT PIN	Be-Cu C17300	GOLD PL./COPPER
INSULATOR	ENGINEERING PLASTIC	N/A
DUST CAP	PVC	N/A

ELECTRICAL CHARACTERISTICS		
IMPEDANCE	50 Ω	
VOLTAGE RATING	335 V(rms)	
FREQUENCY RANGE	0 ~ 40 GHz	
DIELECTRIC WITHSTANDING VOLTAGE	> 500 V	
CONTACT RESISTANCE	CENTER CONTACT	< 3.0 mΩ
	OUTER CONTACT	< 0.2 mΩ
INSULATION RESISTANCE	> 5000 MΩ	
INSERTION LOSS	< 0.05x√F(GHz) dB	
VSWR	< 1.20	
3RD INTERMODULATION	N/A	

MECHANICAL CHARACTERISTICS	
FORCE TO ENGAGE AND DISENGAGE	< 1.4 N (2.4mm)
CENTER CONTACT RETENTION FORCE	> 6 lbs
RECOMMENDED COUPLING TORQUE	7-10 in.lbs
COUPLING NUT RETENTION FORCE	> 60 lbs
DURABILITY	> 500 cycles

ENVIRONMENTAL PARAMETER	
TEMPERATURE RANGE	-40 °C ~ +85 °C

*** CUSTOMER OUTLINE DRAWING**

UNLESS OTHERWISE SPECIFIED:
 1) EDGES : C0.15 MAX ;
 2) REMOVE ALL BURRS ;
 3) SURFACE ROUGHNESS : Ra1.6 ;
 4) UNITS : mm ;
 5) DIMENSIONS TOLERANCES
 DECIMALS : .x ±0.3 .xx ±0.2 .xxx±0.1 ;
 ANGLES : ± 5°.

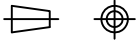
THIRD ANGLE PROJECTION		
APPROVED :	CUSTOMER P/N :	
CHECKED :	SCALE :	1 : 1
DRAWING :	DATE :	2020-05-23
JASON	PAGE :	1/1



TITLE : 2.4mm FEMALE TO 2.92mm MALE ADAPTER

DRAWING NO. : T-5P4F06S-P9M-008

COMPANY WEBSITE : www.slkcorp.com

CUSTOMER OUTLINE DRAWING